

MODE™

CLICK®
ScolmoreGROUP

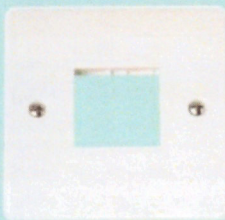

MiniGrid Plate Switches (Modular)



The smooth modern lines of the Mode accessory plate will fit easily into traditional and contemporary designs alike.

Mode switches are developed largely as a modular range based on the large selection of switch modules available in the CLICK MINIGRID Module range. Simple, single screw fixing of modules offers the simplest possible means of installing and replacing modules.

Scolmore International Ltd, 1 Scolmore Park, Landsberg, Lichfield Road Ind. Estate, Tamworth, Staffordshire, B79 7XB

Telephone: 01827 63454

E-mail: sales@scolmore.com, technical@scolmore.com

Facsimile: 01827 63362

Website: www.scolmore.com



MiniGrid Modular Switch Plates (Unfurnished)

Product Range
MiniGrid Modular Switch Plates (Unfurnished)

CMA401	1 Gang Plate Single Aperture
CMA402	1 Gang Plate Twin Aperture
CMA403	1 Gang Plate Triple Aperture
CMA404	2 Gang Plate (2+2) Aperture
CMA406	2 Gang Plate (3+3) Aperture
CMA426	2 Gang Plate 6 In-Line Aperture
CMA432	2 Gang Plate 3 In-Line Aperture



CMA401



CMA402

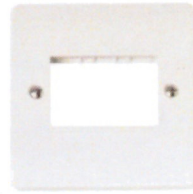

CMA403



CMA404



CMA406



CMA426



CMA432

Errors & Omissions excluded. Specification is subject to change without notice.

V1.0

Scolmore International Ltd, 1 Scolmore Park, Landsberg, Lichfield Road Ind. Estate, Tamworth, Staffordshire, B79 7XB
Telephone: 01827 63454 **Facsimile:** 01827 63362
E-mail: sales@scolmore.com, technical@scolmore.com **Website:** www.scolmore.com

MODE™

CLICK®
ScolmoreGROUP

MiniGrid Modular Switch Plates (Unfurnished)

Product Dimensional Drawings (mm)

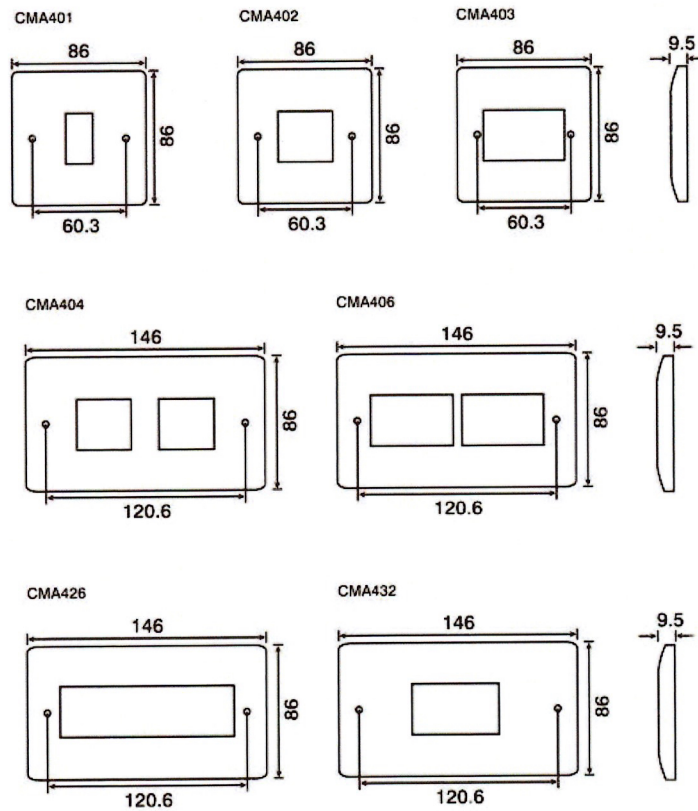

Errors & Omissions excluded. Specification is subject to change without notice.

V1.0

Scolmore International Ltd, 1 Scolmore Park, Landsberg, Lichfield Road Ind. Estate, Tamworth, Staffordshire, B79 7XB

Telephone: 01827 63454

E-mail: sales@scolmore.com, technical@scolmore.com

Facsimile: 01827 63362

Website: www.scolmore.com

MODE™

CLICK®
ScolmoreGROUP

MiniGrid Modular Switch Plates (Unfurnished)

Product Range

MiniGrid Multi-Tier Modular Switch Plates (Unfurnished)

CMA512	12 MiniGrid Module Plate
CMA518	18 MiniGrid Module Plate
GR100PW	6 MiniGrid Module Yoke
WA512	2 Gang Double Row K/O Box 47mm Deep
WA518	2 Gang Triple Row K/O Box 47mm Deep



CMA512

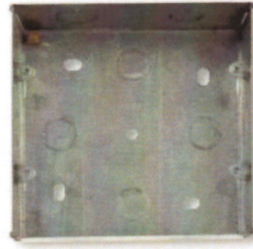

WA512



GR100PW



CMA518

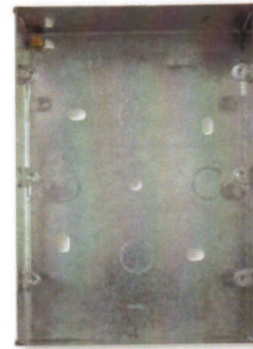

WA518

Errors & Omissions excluded. Specification is subject to change without notice.

V1.0

Scolmore International Ltd, 1 Scolmore Park, Landsberg, Lichfield Road Ind. Estate, Tamworth, Staffordshire, B79 7XB

Telephone: 01827 63454

E-mail: sales@scolmore.com, technical@scolmore.com

Facsimile: 01827 63362

Website: www.scolmore.com

MODE™

CLICK®
ScolmoreGROUP

MiniGrid Modular Switch Plates (Unfurnished)

Product Dimensional Drawings (mm)

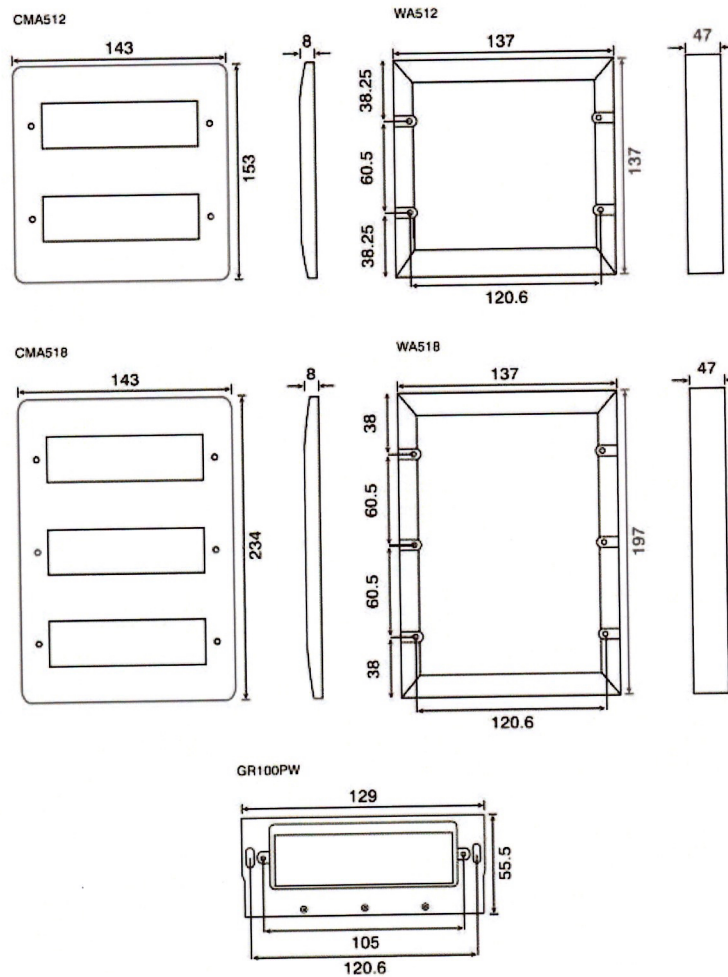

Errors & Omissions excluded. Specification is subject to change without notice.

V1.0

Scolmore International Ltd, 1 Scolmore Park, Landsberg, Lichfield Road Ind. Estate, Tamworth, Staffordshire, B79 7XB
Telephone: 01827 63454
E-mail: sales@scolmore.com, technical@scolmore.com
Facsimile: 01827 63362
Website: www.scolmore.com

MODE™

CLICK®
ScolmoreGROUP

MiniGrid Modular Switch Plates (Unfurnished)

Technical Specification

MiniGrid Multi-Tier Modular Switch Plates (Unfurnished)

Material Composition	Front Plate: Urea GR100 Mounting Yoke: Galvanised Steel & Urea Back Boxes: Galvanised Steel
Cable Size	Dependent on modules fitted
Back Box Depth	Dependent on modules fitted
Modular	Yes
Warranty	20 Years
Anti Microbial Certified	Yes
IP Rating	IP20
Operational Temperature	-5° to +40°C
Standards	BS 5733 : 2010 + A1 : 2014 Modified ISO 22196

Additional Information

Ensure that the mains supply is isolated before commencing installation and refer to the circuit diagram with the relevant product.

Bare earth cables must always be covered with appropriate sleeving and wired to the earth terminal.

All white moulded accessories are manufactured using Urea Formaldehyde, which has similar inherent properties to antimicrobial additives that inhibit the growth of infectious diseases. All products were independently tested and achieved a 99.9% kill rate across all four types of the strains of bacteria - MRSA, E-Coli, Salmonella, and Klebsiella Pneumoniae.

CMA512 requires (2x) GR100 MiniGrid Module Yokes. These plates are designed to be used with specified back box WA512.

CMA518 requires (3x) GR100 MiniGrid Module Yokes. These plates are designed to be used with specified back box WA518.

Interchangeable with modules in the MINIGRID system



Errors & Omissions excluded. Specification is subject to change without notice.

V1.0

Scolmore International Ltd, 1 Scolmore Park, Landsberg, Lichfield Road Ind. Estate, Tamworth, Staffordshire, B79 7XB

Telephone: 01827 63454

E-mail: sales@scolmore.com, technical@scolmore.com

Facsimile: 01827 63362

Website: www.scolmore.com

CLICK MODE

Scolmore
GROUP

Scolmore International Ltd
1 Scolmore Park, Landsberg
Lichfield Road Industrial Estate
Tamworth, Staffordshire B79 7XB
t: 01827 63454
f: 01827 63362
e: sales@scolmore.com
w: www.scolmore.com

DECLARATION OF CONFORMITY

1. **Issuer Name** Scolmore International Limited
2. **Issuer Address** 1 Scolmore Park, Landsberg,
Lichfield Road Industrial Estate,
Tamworth, Staffordshire, B79 7XB
3. **Object(s) of Declaration** Mode Range
 - a. **Group** Modular Switch Plates (Unfurnished)
 - b. **Model No.** CMA401, CMA402, CMA403, CMA404, CMA406, CMA426, CMA512,
CMA518
4. *The object of the declaration described above is in conformity with the requirements of the following Legislations:*
5. *All products contained within the aforementioned comply with the relevant standards and requirements listed below.*

BS 5733 : 2010 + A1 : 2014

6. *I hereby declare that the equipment named above has been designed to comply with the relevant sections of the above referenced specifications. The unit complies with all applicable Essential Requirements of the Directives.*

In conjunction with the above all manufacture and process controls are in accordance with ISO 9001:2008

Signed, for and on behalf of: Scolmore International Limited



Steven Bettson BSc - Senior Technical Support Engineer

CE 15



Company Registration No. 2513009

CLICK OVA