

A Class Heat Pump Cylinders Up to 250L

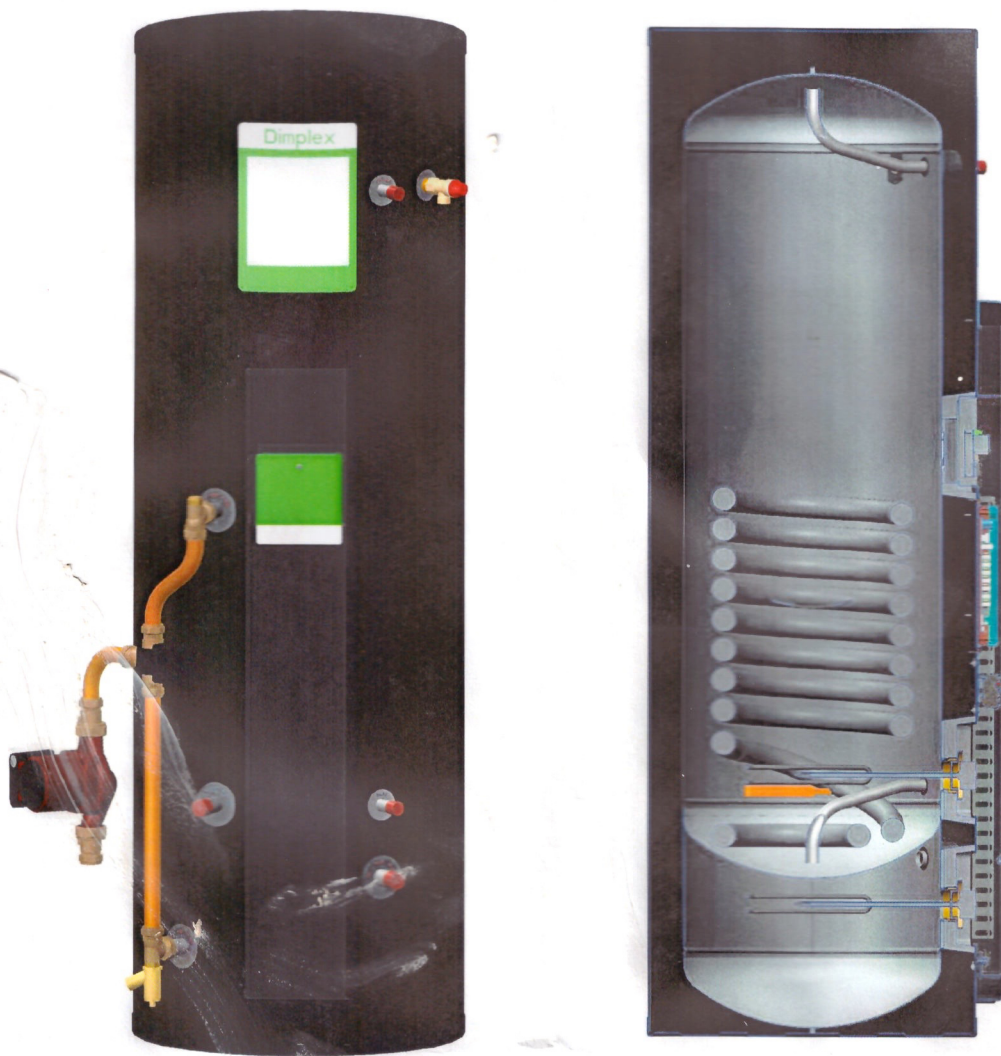

EC-Eau Cylinder Range

Installation and User Instructions

Important - This Manual Must Be Left With The User After Installation!



GDC Group Ltd is a licensed member of the Benchmark Scheme which aims to improve the standards of installation and commissioning of domestic heating and hot water systems in the UK and to encourage regular servicing to optimise safety, efficiency and performance.

Benchmark places responsibilities on both manufacturers and installers. The purpose is to ensure that customers are provided with the correct equipment for their needs, that it is installed, commissioned and serviced in accordance with the manufacturer's instructions by competent persons and that it meets the requirements of the appropriate Building Regulations. The Benchmark Checklist can be used to demonstrate compliance with Building Regulations and should be provided to the customer for future reference.

Installers are required to carry out installation, commissioning and servicing work in accordance with the Benchmark Code of Practice which is available from the Heating and Hot Water Industry Council who manage and promote the Scheme. Visit www.benchmark.org.uk for more information.

The Hot Water Association (HWA) Charter is a code of conduct which requires that all members adhere to the following:

- *supply fit for purpose products clearly and honestly described*
- *supply products that meet, or exceed appropriate standards and building and water regulations*
- *provide pre and post sales technical support*
- *provide clear and concise warranty details to customers*

For further information on HWA Charter Membership, please refer to HWA website www.hotwater.org.uk

All cylinders are certified by KIWA, for further information on this regulation body please refer to the KIWA website www.kiwa.co.uk

0 Overall View

Reference	Description
01	Cold Water Inlet
02	Hot Water Outlet
03	T & P Valve
04	Heat Pump Buffer Flow/HP Flow to Buffer
05	Heat Pump Buffer Flow/Buffer Flow to HP
06	Heat Pump Return/DHw Return
07	Heat Pump Flow/DHw Flow
08	Technical Data Label
09	Electrical Connections
Cylinders Included In This Range	
ECS150HP40A-580	150L HP Cylinder with 40L Buffer
ECS210HP40A-580	210L HP Cylinder with 40L Buffer
ECS250HP40A-580	250L HP Cylinder with 40L Buffer

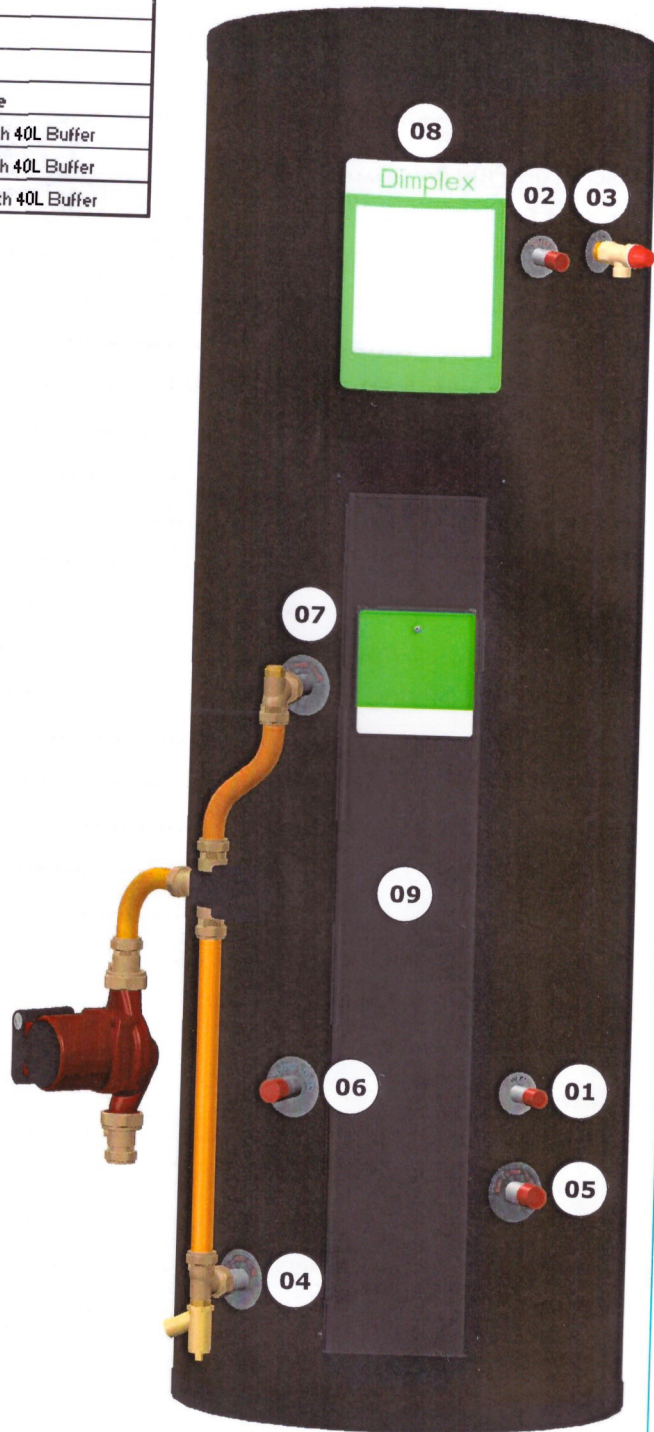

Figure 1: Overall View of **A Class Heat Pump** Cylinder Installation Process

Overall View

1	<u>Contents</u>	
0	Overall View	3
1	Contents	4
2	Introduction	7
3	Scope of Delivery	7
4	Pre-Installation Advice	8
4.1	Risk Assessment	8
4.2	Siting Considerations	8
4.3	Cold Water Supply	9
4.4	Building Regulation G3 Discharge Requirements	9
4.4.1	Discharge Pipe D2	9
4.4.2	Worked Example	11
4.4.3	Termination of Discharge Pipe	11
4.5	Limitations	11
5	Installation	12
5.1	Cold Water Inlet with Inlet Control Group	12
5.1.1	Correctly Site the Cylinder	12
5.1.2	Install the Inlet Group	12
5.1.3	Expansion Vessel	12
5.1.4	Balanced Cold Water Supply	12
5.1.5	Drain Valve	12
5.2	Hot Water Outlet	13
5.2.1	Thermostatic Mixing Valve	13
5.2.2	Pipe Insulation	13
5.3	Discharge Pipes from Safety Devices	13
5.3.1	Discharge Pipe D1	13
5.3.2	Discharge Pipe D2	13
5.3.3	Tundish	13
5.4	HP Flow to Buffer Connection	13
5.5	Buffer Flow to HP Connection	13
5.6	Coil Return Connections	14
5.7	Coil Flow Connections	14
5.8	Temperature Sensor Connection	16
5.8.1	Temperature Sensor Connection Thermostat Housing	16
5.9	Water Module Wiring	19
5.9.1	Primary Electrical Connections	19
5.9.2	Modbus Connection	20
5.9.3	Zone Connections	21
5.9.4	Digital Inputs & Temperature Sensors	22
5.10	Bivalent System	23
5.11	Connection of Secondary Return	23
6	Commissioning	24

7 Maintenance	25
8 Spare Parts	26
9 Technical Data and Product Fiche	27
9.1 A Class Heat Pump Buffer Range	27
9.2 Cylinder Heat Exchanger Pressure Drop.....	30
9.3 Cylinder Attainable Temperature	30
10 User Instructions	31
10.1 General	31
10.2 Operation	31
10.3 Water Temperature Direct Electric Heating	31
10.4 Maintenance	31
10.5 Troubleshooting	32

Precaution: *This appliance can be used by children aged from 8 years and above and persons with reduced physical, sensory or mental capabilities or lack of experience and knowledge if they have been given supervision or instruction concerning use of the appliance in a safe way and understanding the hazards involved. Children shall not play with the appliance. Cleaning and user maintenance shall not be made by children without supervision.*

Note: **Between the inlet group and the cold water inlet on the cylinder NO isolating device may be fitted, as by doing so important safety devices could be isolated!**



It is important to check the pre-charge pressure of the expansion vessel membrane before filling the cylinder. This has been factory set to 3 bar. The pre-charge should be greater than or equal to 3 bar.



It is important that the tundish is positioned away from any electrical components.

Note: **Means for electrical disconnection must be incorporated in the fixed wiring in accordance with the wiring rules.**



Before removing the cover from the immersion heater isolate appliance using isolating switch! Danger of electrical shock! Only use suitable electrically insulated equipment when working inside immersion housing.



The maintenance of this appliance must be carried out by a suitably qualified person only. It is recommended to maintain the unit on an annual basis. Isolate all electrical supplies from the unit before commencing work. Danger of electrical shock!



CLEANING INSTRUCTIONS:
Clean outer cladding of cylinder with a soft cloth dampened with warm water only. Do not use abrasive or aggressive cleaning materials, such as alcohol or petroleum based solvents, as this may damage the surface of the product.

Temperature setting: **A high level cutout is fitted to the product for each heat source. This should never activate under normal operation. The maximum possible cylinder temperature attainable by the heat pump is 65°C as set on the User Interface. The back-up immersion heater can produce up to 72°C at its maximum setting, i.e. 5. For convenience the immersion heater is preset to produce 60°C.**

If an electronic copy of this manual should be required, please contact the manufacturer at the address at the back of this manual.

For further information on product warranty please refer to R01020-3 Terms and Conditions Manual.

2 Introduction

Thank you for choosing a Dimplex product. The EC-Eau heat pump cylinders are specified with large, high surface area heat exchangers, specifically sized to match the requirements of Dimplex "A" Class Heat Pumps. They boast 60mm of low GWP insulation foam, together with 100% recyclable stainless steel inner components and a sleek black, hard wearing outer shell manufactured from completely recycled materials.

NOTE: This product has been designed specifically for the purpose of delivering heated, domestic and sanitary hot water as part of a pressurised water heating system. The package is provided with fittings that comply with Section G3 of Building Regulations.

WARNING: Dimplex cannot take responsibility for ensuring safe operation of the appliance outside of the scope of intended use.

For more detailed information on product features, please see the Technical Data section in this manual.

3 Scope of Delivery

Please ensure you check the scope of delivery below before signing any delivery documentation. Claims for missing or damaged parts after signing for the delivery will not be accepted.













Scope of delivery				
Cylinder nominal volume		150/40 l	210/40 l	250/40 l
Cylinder with two 3kW immersions *		✓	✓	✓
T+P valve *		1/2", 7bar/90°C	1/2", 7bar/90°C	1/2", 7bar/90°C
Inlet control group consisting of:-		✓	✓	✓
- in line strainer				
- 3 bar PRV				
- 6 bar ERV				
- non-return valve				
- balanced cold water supply port				
- 22mm connection for expansion vessel				
28mm motorised three port valve **		✓	✓	✓
28mm Drain Valve and T-Piece Asm		✓	✓	✓
28mm Bleed Valve and T-Piece Asm		✓	✓	✓
28mm S Bend CU Pipe		✓	✓	✓
28mm CU Straight Pipe		✓	✓	✓
28mm x 90 Pipe		✓	✓	✓
Expansion vessel with fixing kit and connection hose		12 l	18 l	24 l
Tundish		15mm/22mm	15mm/22mm	15mm/22mm
Cable ties x 10		✓	✓	✓
Installation & User Instructions x 1		✓	✓	✓
Terms and conditions x 1		✓	✓	✓

Table 1: Scope of Delivery for **A Class Heat Pump** Cylinders

* These items are supplied factory fitted

** Supplied with Dimplex heat pump hydraulic pack

4 **Pre-Installation Advice**

Please read the following section carefully before commencing installation. If in any doubt, please call the appropriate help desk. Disregarding the instructions given in this manual in its entirety and any relevant regulations, standards and codes of practice will void the guarantee of this product.

- **Handling** – depending on the size of the unit and access to its installation location, consideration must be given to the handling of the unit. Please note that handling, installation and use of this product is subject to the Health and Safety at Work Act. If the unit is not installed immediately, it should remain in its protective packaging with all pipe protectors/end caps applied to prevent damage and dirt deposit inside the cylinder and the coils.
- **Pipe Work** – the pipe runs should be executed as short as possible, unused pipe work should be removed and all remaining pipe work should be lagged in accordance with regulatory requirements to prevent heat loss and the formation of condensation.
- **Taps and Fittings** – all taps and fittings incorporated in the unvented system should have a rated operating pressure of 0.6 MPa (6 bar) or above.

4.1 Risk Assessment

The compilation of a risk assessment is strongly recommended before installing the product. The following areas require particular consideration in addition to the information required by the Health and Safety at Work Act.

- scalding: where appropriate or required by law a thermostatic mixing valve is to be fitted to the hot water outlet of the cylinder (see also water borne organisms).
- explosion: the unit is fully equipped with all relevant safety equipment to comply with current regulations. The correct design and function has been verified by independent third party testing. The correct application thereof is the responsibility of the competent installer.
- water borne organisms (i.e. Legionella): if applicable a risk assessment should be carried out following the recommendations outlined in the Approved Code of Practice L8.

- the user preference must be considered when commissioning the system, in particular when adjusting the temperature and timer settings.

4.2 Siting Considerations

When choosing a suitable location for the cylinder the following aspects should be considered:

- structural integrity
- access for installation, operation, maintenance and replacement
- routing of discharge pipe work
- access to water mains supply, hot and cold water distribution pipe work
- access to suitable electricity supply
- location in relation to remaining system components such as auxiliary system
- frost protection

The heat pump cylinder range is designed to be floor standing, vertically mounted, indoors and in a frost free environment. The cylinder may be located on any flat and level surface, provided it is sufficiently robust to support the weight of the cylinder when full of water (please see technical data) and suitably accessible for replacement/maintenance without specialist tools or lifting equipment as this will void the warranty conditions.

The position and orientation of the cylinder should be such that easy access is provided for servicing the controls. A minimum distance of 400mm in front of the immersion is recommended, to allow the replacement of the immersion heater should the need arise. When installing the cylinder all labels should be clearly visible and ensure that no pipework hinders any work to be carried out on the various cylinder components.

Particular care must be taken when placing the cylinder in a garage or outbuilding. All exposed pipe work must be correctly insulated to avoid frost damage.



CLEANING INSTRUCTIONS: *Clean outer cladding of cylinder with a soft cloth dampened with warm water only. Do not use abrasive or aggressive cleaning materials, such as alcohol or petroleum based solvents, as this may damage the surface of the product.*

4.3 Cold Water Supply

For satisfactory and safe performance of the unvented cylinder the water supply must meet the following criteria:

Minimum dynamic pressure	150 kPa (1.5 bar)
Maximum inlet supply pressure	1200 kPa (12 bar)
Minimum flow rate	15 l/min
Max. chlorine content	250mg/L
Max. water hardness	200mg/L

The following instructions have to be followed when installing the cold water mains supply to the cylinder:

- The cold water supply to the cylinder must come directly from the cold water mains after the mains stop valve to the property.
- The cold water inlet pipe work should have at least an inside diameter of 19mm and should meet the requirements of the water regulations for the supply of wholesome water.

Dimplex recommend an annual maintenance inspection is carried out on the domestic hot water cylinder. In hard water areas this should include inspection of the heat exchanger and immersion heater, [above 120ppm or 120mg/l]. A local water treatment company should be able to offer free water quality testing. The heating elements may require periodic de-scaling. The installer should do this as part of a maintenance agreement.

If required, precautions can be taken to minimise effects of water hardness, i.e. installation of water conditioner or water softener. These devices should be installed in hard water areas where high water storage temperatures are required, i.e. greater than 60°C storage temperatures, particularly when water hardness exceeds 200ppm. Should the water cylinder require de-scaling, this must be performed by a qualified technician.

4.4 Building Regulation G3 Discharge Requirements

As part of the requirements of Building Regulation G3 any discharge from an unvented system should be conveyed to where it is visible, but will not cause danger to persons in or about the building. The tundish and the discharge pipes should be fitted in accordance with the requirements of Building Regulation approved document G3, (England and Wales), Part P of Northern Ireland and Standard 4.9 of Scotland.

4.4.1 Discharge Pipe D2

The discharge pipe (D2) from the Tundish should:

- *"have a vertical section of pipe at least 300mm long below the tundish before any elbows or bends in the pipework and be installed with a continuous fall of at least 1 in 200 thereafter."*

The discharge pipe (D2) should be made of:

- *"metal; or other material that has been demonstrated to be capable of safely withstanding temperatures of the water discharged and is clearly and permanently marked to identify the product and performance standard."*

It is strongly recommended that only metal pipework should be used. No responsibility will be taken for any damage caused from discharges.

The discharge pipe D2 should be at least one pipe size larger than the nominal outlet size of the safety device unless its total equivalent hydraulic resistance exceeds that of a straight pipe 9m long, i.e. For discharge pipes between 9m and 18m the equivalent resistance length should be at least two sizes larger than the nominal outlet size of the safety device; between 18 and 27m at least 3 sizes larger, and so on; bends must be taken into account in calculating the flow resistance. See Figure 2, Table 2 and the worked example.

Note: An alternative approach for sizing discharge pipes would be to follow Annex D, section D.2 of BS 6700:2006 + A1:2009).

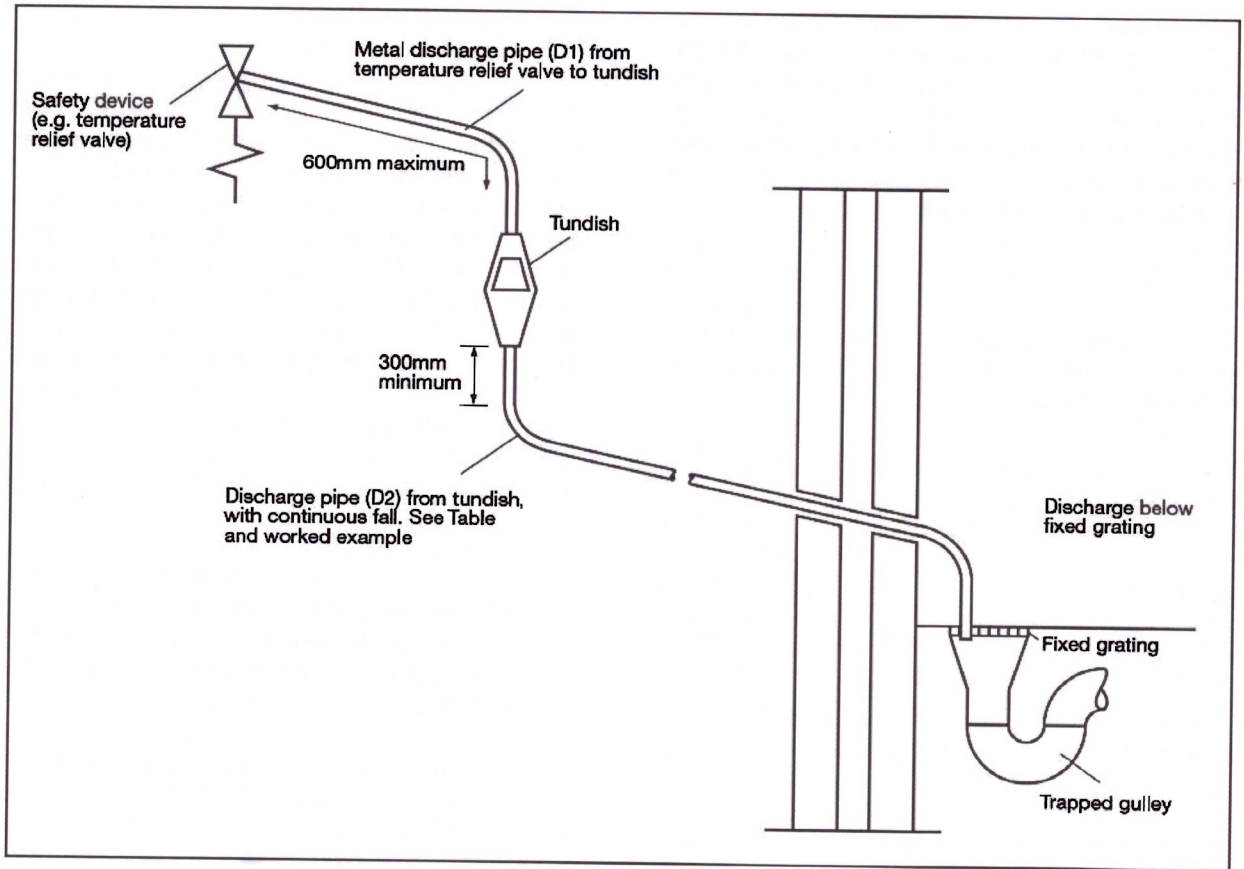

Figure 2: Typical Discharge Pipe Arrangement

Valve outlet size	Minimum size of discharge pipe before tundish	Minimum size of discharge pipe after tundish	Maximum allowed length of pipe after tundish	Length to be subtracted for each elbow or bend
[-]	[mm]	[mm]	[m]	[m]
G1/2	15	22	9	0.8
		28	18	1.0
		35	27	1.4
G3/4	22	28	9	1.0
		35	18	1.4
		42	27	1.7
G1	28	35	9	1.4
		42	18	1.7
		54	27	2.3

Table 2: Sizing of Copper Discharge Pipe "D2" for Common Temperature Relief Valve Outlet Sizes

4.4.2 Worked Example

This example is for a G½ temperature relief valve with a discharge pipe (D2) (as fitted on 125 to 300L cylinders) having 4 No. 22mm elbows and length of 7m from the tundish to the point of discharge.

From Table 2, the maximum resistance allowed for a straight length of 22mm copper discharge pipe (D2) from a G½ temperature relief valve is 9.0m. Subtract the resistance for 4 No. 22mm elbows at 0.8m each = 3.2m.

Therefore the maximum permitted length equates to 5.8m, which is less than the actual length of 7m, therefore calculate the next largest size.

Maximum resistance allowed for a straight length of 28mm copper discharge pipe (D2) from a G½ temperature relief valve is: 18m

Subtract the resistance for 4 No. 28mm elbows at 1.0m each = 4m

Therefore the maximum permitted length equates to 14m.

As the actual length is 7m, a 28mm (D2) copper pipe will be satisfactory.

- Where a single common discharge pipe serves more than one system, it should be at least one pipe size larger than the largest individual discharge pipe (D2) to be connected.
- The discharge pipe should not be connected to a soil discharge stack unless the soil discharge stack is capable of safely withstanding temperatures of the water discharged, in which case, it should:
 - contain a mechanical seal, which allows water into the branch pipe without allowing foul air from the drain to be ventilated through the tundish.
 - there should be a separate branch pipe with no sanitary appliances connected to it.
 - if plastic pipes are used as branch pipes carrying discharge from a safety device, they should be either polybutalene (PB) or cross-linked polyethylene (PE-X) complying with national standards.

- be continuously marked with a warning that no sanitary appliances should be connected to the pipe.

4.4.3 Termination of Discharge Pipe

- "The discharge pipe (D2) from the tundish should terminate in a safe place where there is no risk to persons in the vicinity of the discharge."

Examples of acceptable discharge arrangements are:

- "to a trapped gully with the end of the pipe below a fixed grating and above the water seal;
- downward discharges at low level; i.e. up to 100mm above external surfaces such as car parks, hard standings, grassed areas etc. are acceptable providing that a wire cage or similar guard is positioned to prevent contact, whilst maintaining visibility; and,
- discharges at high level: e.g. into a metal hopper and metal downpipe with the end of the discharge pipe clearly visible or onto a roof capable of withstanding high temperature discharges of water and 3m from any plastic guttering system that would collect such discharges."

Note: As the discharge would consist of high temperature water and steam, asphalt, roofing felt and non-metallic rainwater goods may be damaged by such discharges.

4.5 Limitations

- The heat pump must be specified correctly, to ensure it is compatible with the model of cylinder installed. This is to prevent the heat pump malfunctioning when preparing domestic hot water.
- The heat exchangers in this range of cylinders have been specifically designed for heat pump applications. Great care must be taken if using these cylinders with other heat sources, due to the heat exchange capacity of the product.

5 Installation

5.1 Cold Water Inlet with Inlet Control Group

5.1.1 Correctly Site the Cylinder

Install the cylinder in an appropriate location, ensuring all of the recommendations have been considered (see chapter 4.2).

5.1.2 Install the Inlet Group

The inlet group regulates the pressure of the incoming mains water supply to the cylinder and removes any debris that might be water borne.

Note: Between the inlet group and the cold water inlet on the cylinder NO isolating device may be fitted, as by doing so important safety devices could be isolated!

5.1.3 Expansion Vessel

The expansion vessel is mandatory on all EC-Eau cylinders and can be connected directly to the cold water inlet group, utilising the flexible hose supplied with the vessel. The expansion vessel should always be fitted in accordance with the manufacturer's instructions. Isolating device/s must not be fitted between the water cylinder, the expansion vessel and the cold water inlet group.

Furthermore, it is recommended to mount the vessel higher than the cylinder to avoid having to drain the cylinder when maintaining and replacing the expansion vessel.

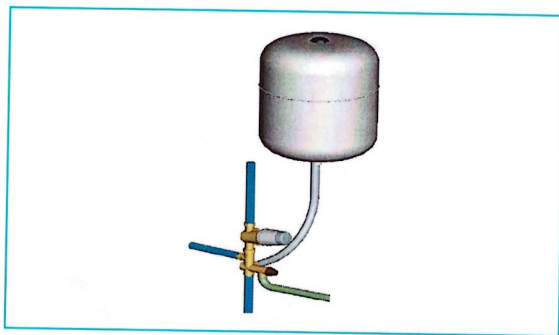

Figure 3: Connection Of The Expansion Vessel To The Inlet Group



It is important to check the pre-charge pressure of the expansion vessel membrane before filling the cylinder. This has been factory set to 3 bar. The pre charge should be greater than or equal to 3bar.

Note: The expansion vessel must be installed to the side of the expansion relief valve on the inlet group. To do this the blanking plug must be removed and the expansion vessel connected, as shown in Figure 4.

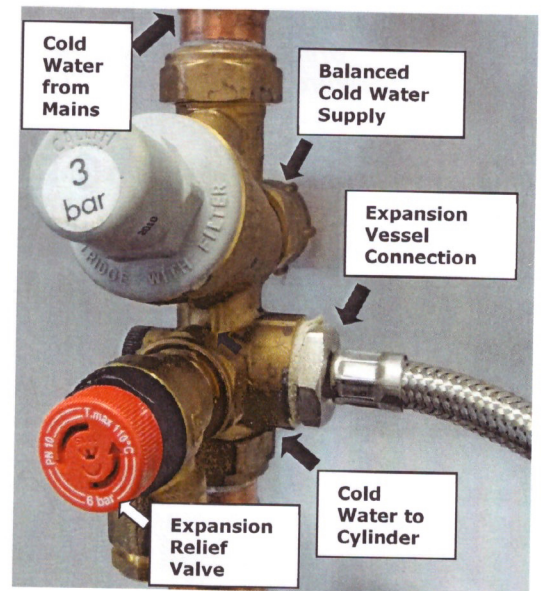

Figure 4: Detail Showing The Connection Of The Expansion Vessel To The Inlet Group

5.1.4 Balanced Cold Water Supply

If a balanced cold water supply is required (recommended) a connection can be taken from the bottom of the inlet group.

5.1.5 Drain Valve

It is also recommended to install a drain valve in the lowest point of the cold water feed to the cylinder. This allows the cylinder to be drained in a controlled manner should this become necessary.

5.2 Hot Water Outlet

The hot water pipe work is to be directly connected to the hot water outlet connection on the cylinder, see Figure 1.

5.2.1 Thermostatic Mixing Valve

A thermostatic mixing valve may be required to limit the outlet temperature. In this case, the valve should be installed following the manufacturer's instructions, ensuring none of the safety equipment has been isolated, (i.e. make sure the connection to the thermostatic mixing valve is taken after the safety equipment of the inlet group).

5.2.2 Pipe Insulation

It is recommended to insulate the hot water pipe work from the cylinder to the outlets, to reduce the energy requirements for providing hot water. It is also recommended to insulate all other exposed pipework, such as the T&P to the tundish, the coil flow and return and the cold water inlet pipes.

5.3 Discharge Pipes from Safety Devices

5.3.1 Discharge Pipe D1

- The temperature and pressure relief valve must be discharged directly or by way of a manifold via a short length of metal pipe (D1) into a tundish; and the discharge pipe must be installed in a continuously downward direction and in a frost free environment. Water may drip from the discharge pipe of the pressure relief device and this pipe must be left open to the atmosphere.
- The diameter of discharge pipe (D1) should not be less than the nominal outlet size of the safety device, e.g. temperature relief valve.
- Where a manifold is used it should be sized to accept and discharge the total discharge from all the D1 discharge pipes connected to it.
- The discharge pipe work from the expansion relief valve must be installed constantly falling to an open point of discharge. It is recommended to combine it with the discharge of the temperature and pressure relief valve.

Note: The T&P valve is pre-sealed and if moved the seal will be broken, should this occur, it will need to be resealed with an appropriate sealant (part number R00836-1).

5.3.2 Discharge Pipe D2

For a detailed description of the discharge pipework D2 see chapter 4.4.1.

5.3.3 Tundish

- The tundish should be vertical, located in the same space as the unvented hot water storage system and be fitted as close as possible to, and lower than, the safety device, with no more than 600mm of pipe between the valve outlet and the tundish (see Figure 2).
- Discharge should be visible at the tundish, where discharges may not be apparent, e.g. in dwellings occupied by people with impaired vision or mobility, consideration should be given to the installation of a suitable safety device to warn when discharge takes place, e.g. electronically operated.

Note: To comply with the Water Supply (Water Fittings) Regulations, the tundish should incorporate a suitable air gap.



It is important that the tundish is positioned away from any electrical components.

Note: The cylinder must be filled with water before switching on the immersion heater. Failure to do so will damage the element and void any guarantee on the product.

5.4 HP Flow to Buffer Connection

The cylinder buffer flow connection must be connected to the three port valve, connection B. See Figure 5.

5.5 Buffer Flow to HP Connection

The cylinder buffer flow to HP connection must be connected in series with the heat emitter system/under floor heating.

5.6 Coil Return Connections

If the return connection is the lowest point in the heat pump loop, a suitable drain device should be installed. For location of connections see Figure 1.

It is recommended that the fittings used to connect to the cylinder are suitable for stainless steel, the flow and return should use 28mm compression fittings. Not all push fit fittings can be used – please check with your supplier. When using compression fittings, ensure that the connection is not over-tightened.

5.7 Coil Flow Connections

If the flow connection is the highest point in the heat pump loop and if the system was not commissioned using a flush and fill pump, an adequate device for de-aeration must be installed. The coil flow connection must be connected to the A connection of the three port valve. See Figure 5.

Note: Special care is required when fitting the 3 port valve to ensure "A" goes to the DHW coil and that "B" goes to the buffer. This is different to the normal convention that may be used.

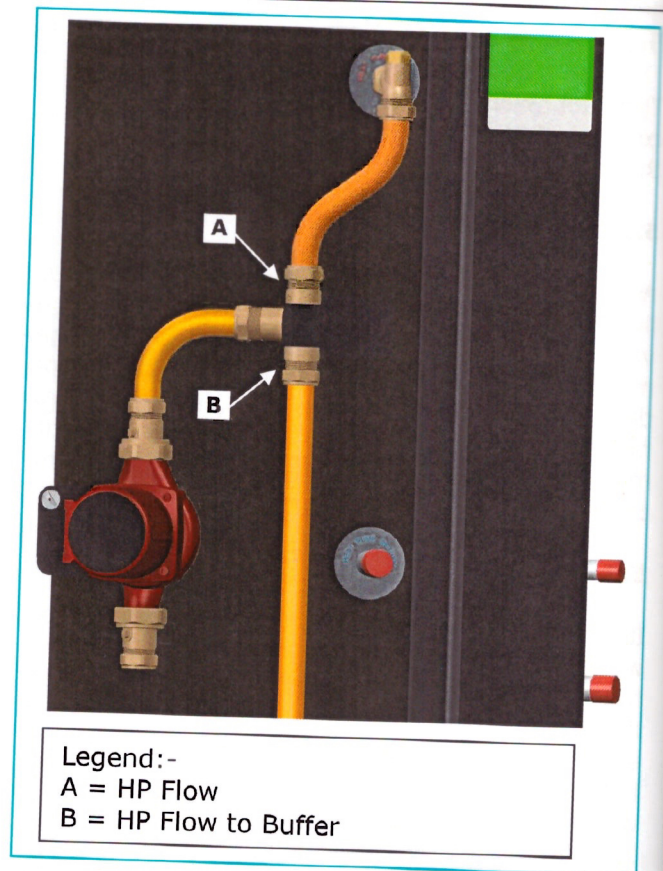

Figure 5: Diagram Showing Positions of Valve

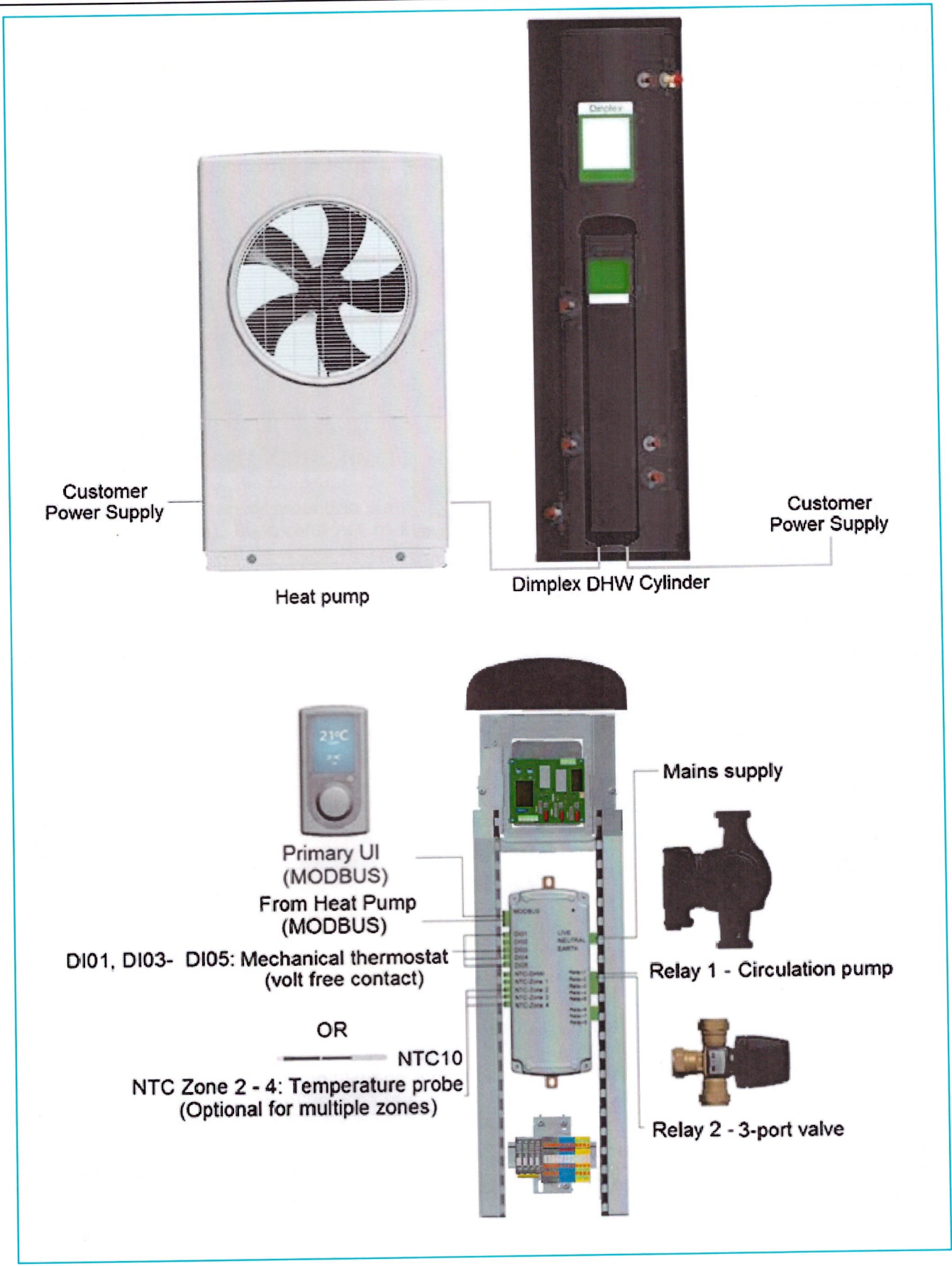

Figure 6: Wiring Configuration of Space Heating and Hot Water - Dimplex "A Class" Cylinder

Installation

5.8 Temperature Sensor Connection

5.8.1 Temperature Sensor Connection Thermostat Housing



Step 1: Access the sensor mounting plate. To do this remove the hood (A) by removing the fixing screws at the bottom sides.

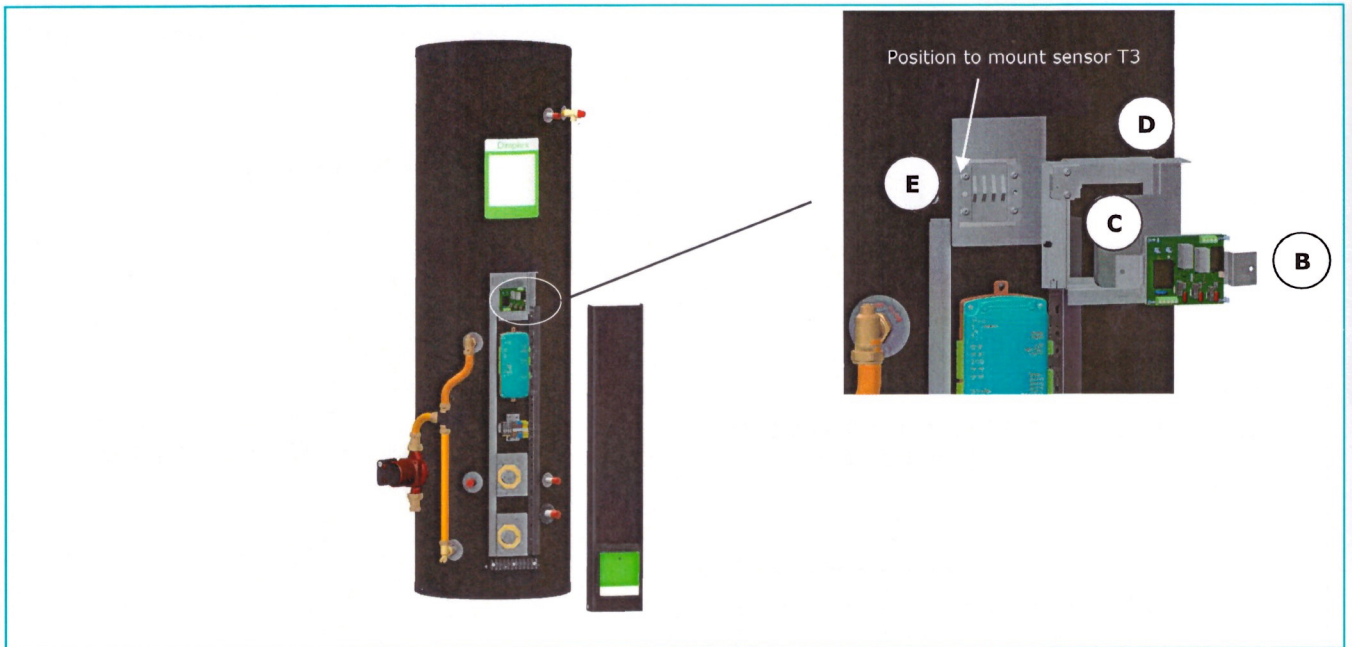

Step 2: Remove the PCB board assembly (B), the insulation foam (C) and the relay housing bracket (D), to access the sensor mounting plate (E) and remove the M5 fixing screws in the four corners of the plate, when mounting the sensor.

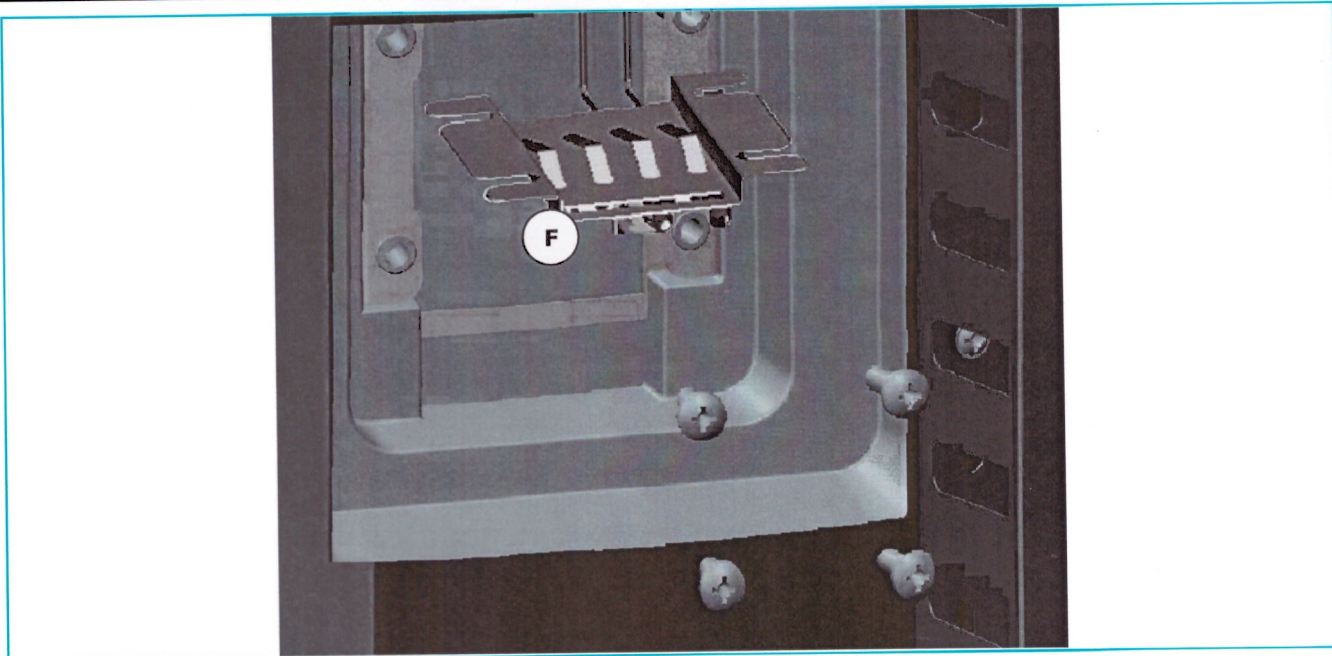

Step 3: Orientate the sensor mounting plate to allow access to the phials (four clips in the centre of the sensor mounting plate). Be careful not to kink the capillaries that connect the thermostat bulbs. The sensor mounting plate will have two vacant slots for additional sensors (F). Repeat for both positions.

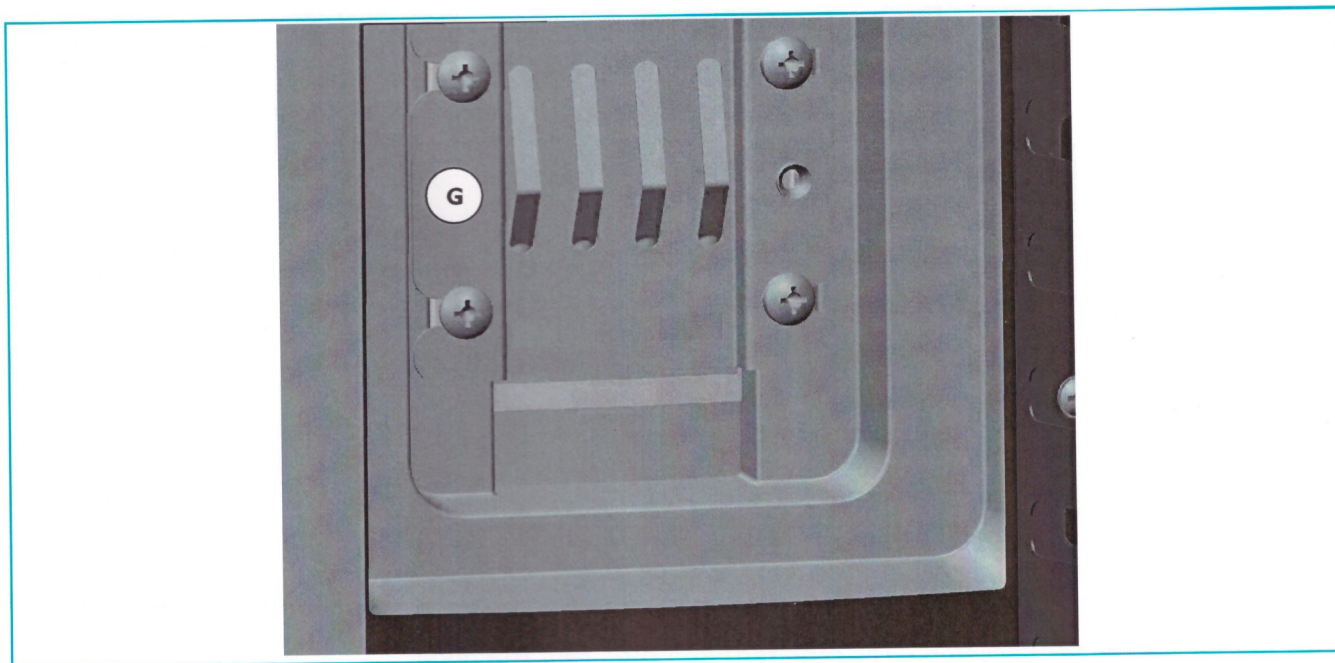

Step 4: Move the sensor mounting plate back into its fixing position. Be careful not to kink the capillaries that connect the thermostat bulbs. Fit the four M5 fixing screws into the cylinder bracket (G). Tighten the screws until the thermostat bulbs and heat pump sensor are held firmly against the wall of the inner cylinder. Repeat for both positions.

Note: there should be no movement in the phials that are used to hold the bulbs and sensor. Care should be taken not to overtighten the screws.

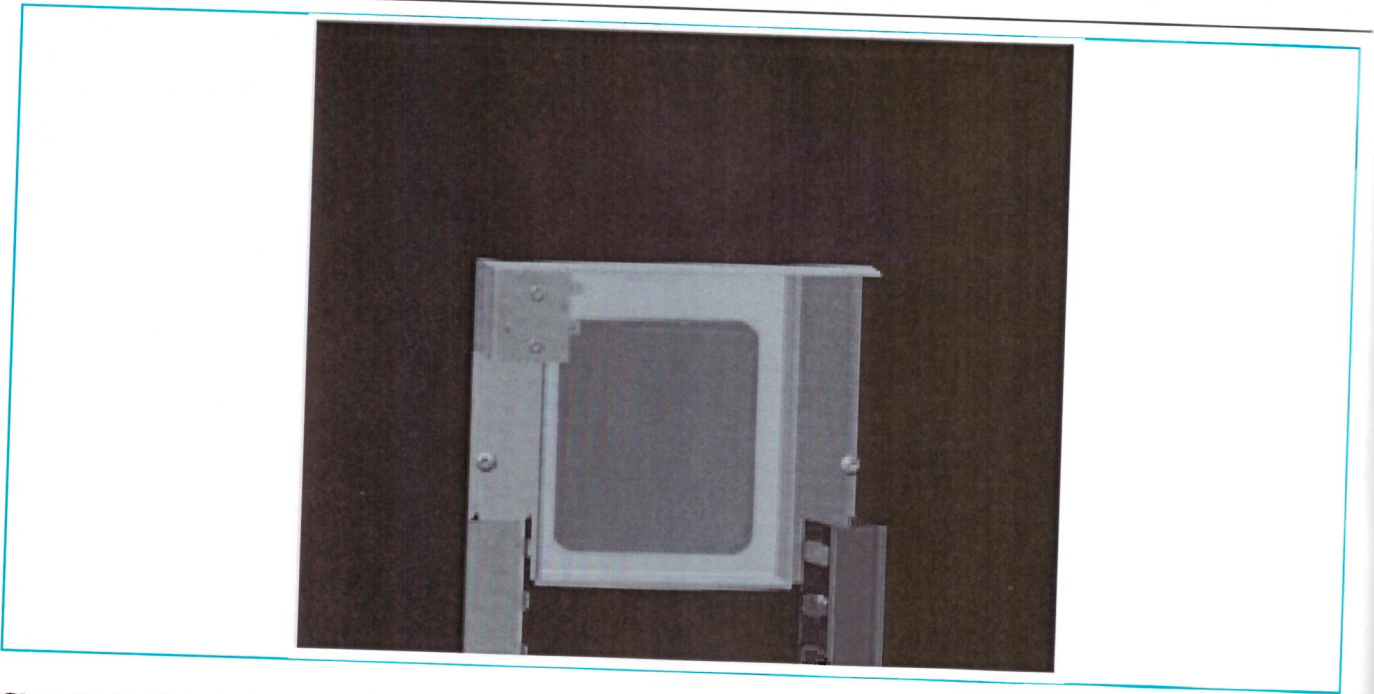

Step 5: Replace the insulating foam over the sensor mounting plate.

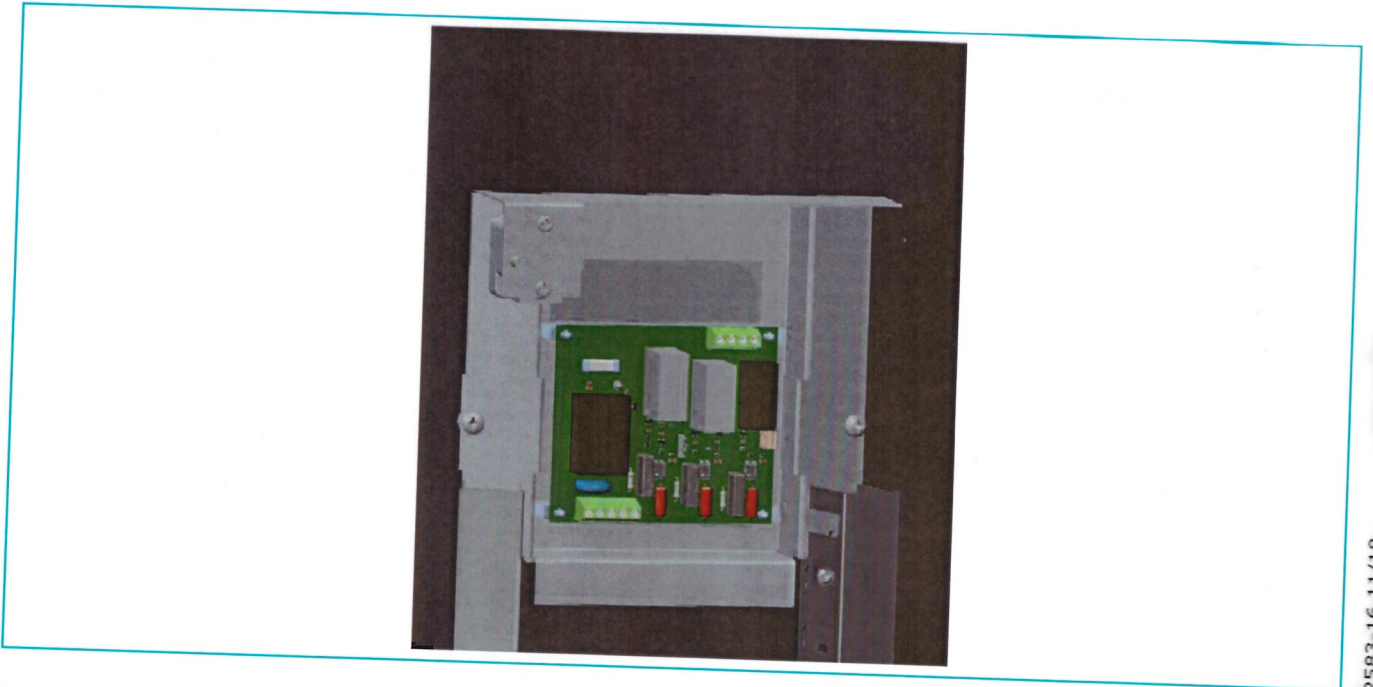

Step 6: Replace the PCB assembly (as required) and then refit the hood.

5.9 Water Module Wiring

All wiring must be carried out by a suitably qualified person and must be fully compliant with the current release of Building & Wiring Regulations. For general wiring configuration see Figure 7.

The water module has been pre-wired to ensure minimal additional work is required by the installer. The following summarises the required electrical connections which the installer must make:

- Primary connections, 5.9.1. A three core cable must be connected between the supply isolator and the cylinder connector block. See Figure 7.
- Modbus connection, 5.9.2 The communication cable between the cylinder and heat pump must be installed. See Figure 9.
- Zoned connections must be wired via the cylinder PCB, i.e. circulation pumps and/or zone valves, 5.9.3. See Figure 10.
- Temperature sensors and digital inputs can be connected to the PCB, 5.9.4 (DI 01-05), (NTC-DHW and NTC-Zone 1-4). See Figure 11.

5.9.1 Primary Electrical Connections

In both retro fit and new build installations, a 3 core cable must be taken from the isolator [typically a 16Amp double pole fused spur] and connected to the primary connector block as illustrated in Figure 7.

- Live connection taken from a fused spur to the cylinder connector block, [LHS grey terminal].
- Neutral and Earth wires must be connected to the blue and green/yellow connectors respectively, as per Figure 7.

Note: Solid core cable or ferruled multi core cable must be used on the primary connector block.

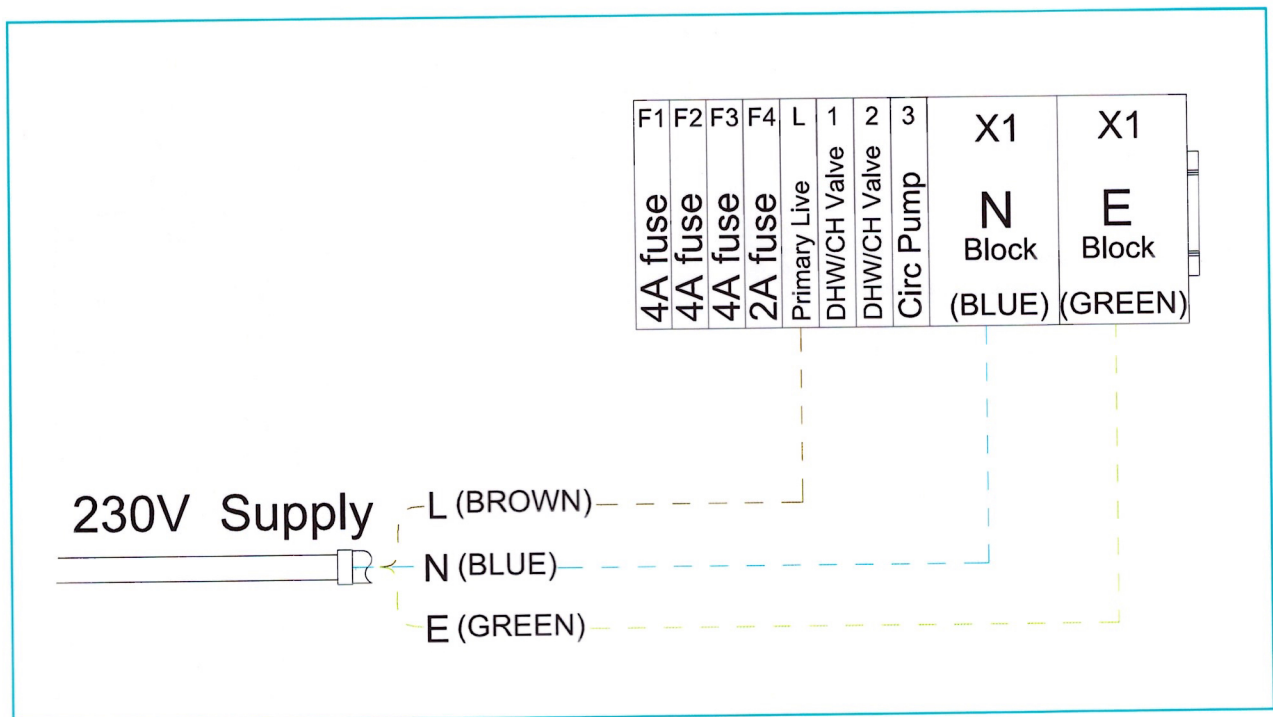

Figure 7: Primary Electrical Connections, Live, Neutral & Earth

5.9.2 Modbus Connection

Correct installation of the Modbus connections is critical for communication between the heat pump, UI and the cylinder. Figure 9 illustrates how these connections must be made. The modbus wire must be specified to BELDEN 9842. The maximum allowable network length is 100m.

- Modbus in connection comes from the heat pump master controller.
- Modbus out connection goes to the user interface.
- The earth shield of the Modbus cable must be connected to ground at both ends. The Earth connector block, the relay housing bracket faston tab connection (1) or the Jill nut screw (2) can all be used for this, see Figure 8.
- The Modbus cables can be fed inside the low voltage trunking (LHR) under the metal hood and clamped to the strain relief bar, using the supplied cable ties.

Note: The earth shield in the cable from the heat pump to the cylinder is only terminated at the cylinder.

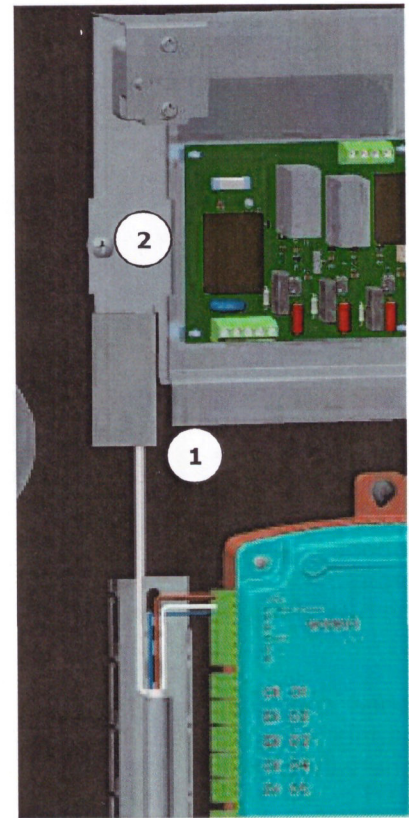

Figure 8: Modbus Earth Connection on relay housing bracket

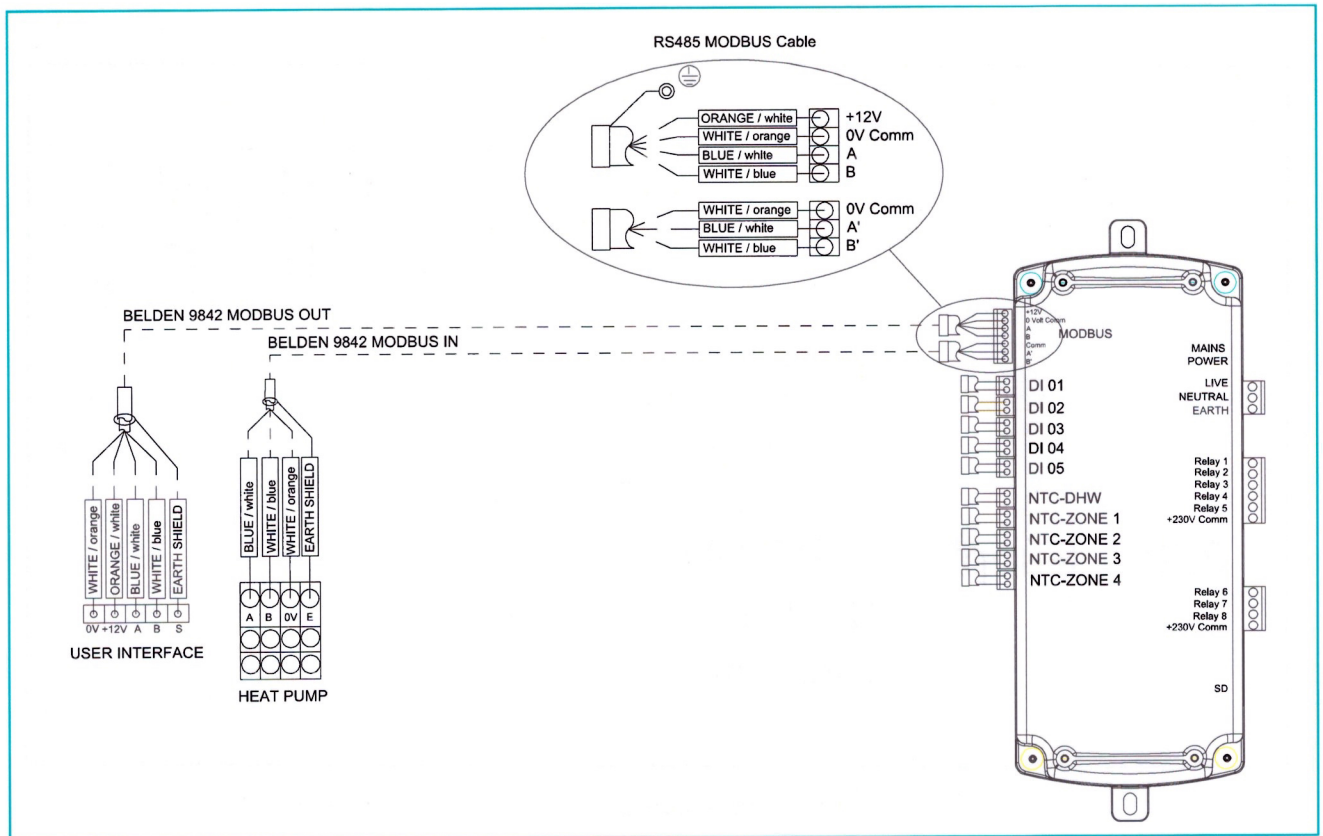

Figure 9: Modbus Communication Connection

5.9.3 Zone Connections

- For a dual zone system, i.e. DHW and Central Heating, a pump and a three port valve is required; these are included in the scope of delivery of the heat pump hydraulic pack.
- Where additional zones are required, the installer must specify and source suitable components. Figure 10, illustrates wiring of each pump and/or zone valve for up to 4 zones.

Note: The water module PCB is only capable of switching valves and under no circumstances should ERP pumps be switched, as irreparable damage will be caused that will void the warranty.

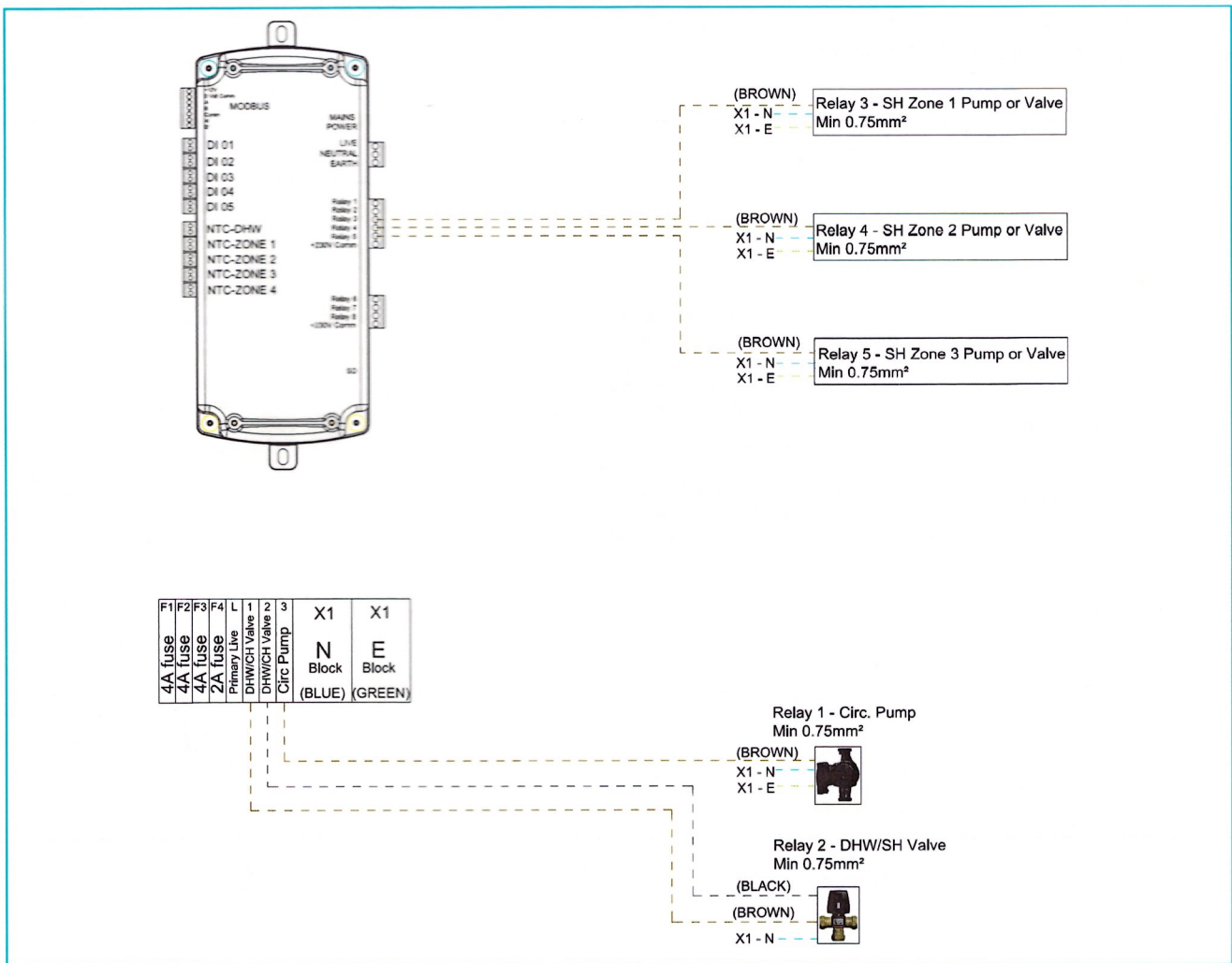

Figure 10: Zone Connection

5.9.4 Digital Inputs & Temperature Sensors

The water module contains 5 optional digital inputs, 4 optional NTC zone temperature sensor inputs and 1 domestic hot water (DHW) NTC sensor.

- DHW NTC is pre-wired and fitted to the cylinder. This sensor allows the user interface to display the actual cylinder temperature.
- NTC zone sensors allow the user interface to display room temperature in up to 4 different zones and actuate the corresponding controls accordingly.

- Digital input 1 is a spare connection.
- Digital input 2 is pre-wired and enables/inhibits remote control.
- Digital inputs 3, 4 & 5 accept room thermostat connections (volt free) that can be used to control ambient temperature at each zone.

Note: The DI's are volt free and under no circumstances should 240V be connected to these, as irreparable damage would result and void the warranty.

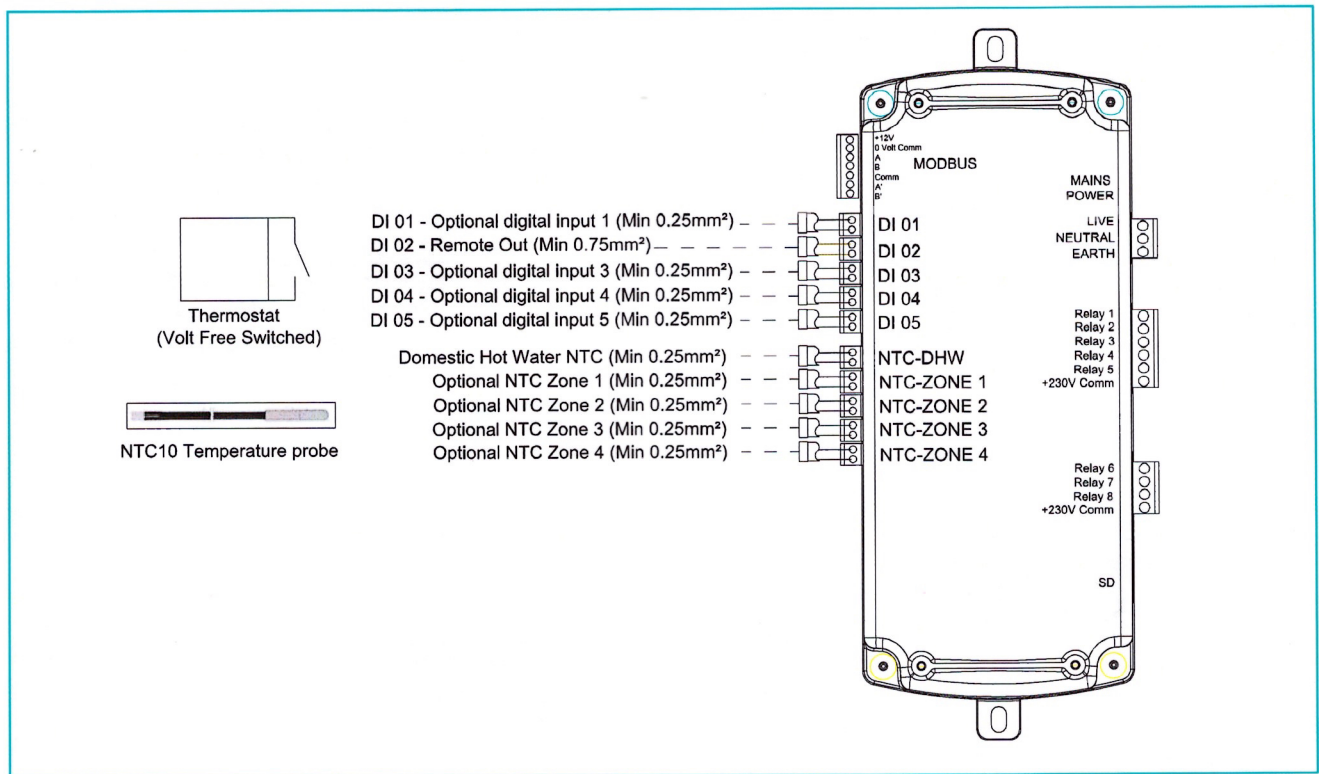

Figure 11: Digital Inputs & Temperature Sensors

5.10 Bivalent System

Bivalent system operation can be achieved by disconnecting the buffer cylinder live connection [A] and connecting the backup heat source.

5.11 Connection of Secondary Return

For cylinders that do not have a dedicated secondary return connection, it is possible to install a secondary return by connecting a swept - T to the cold water inlet of the cylinder (see Figure 12).

The secondary return pipe should incorporate a check valve and a WRAS approved circulation pump; timer and thermostat to be provided separately. Where secondary return circuits are used, then an additional expansion vessel may be required.

The secondary return loop must avoid

- stagnant water in long pipe runs
- long waiting times at draw off point for hot water
- undue water wastage

To minimise the energy consumption of the secondary return circuit and to ensure reliable operation it is important to consider:

- the control of the circulation pump to be time and temperature controlled

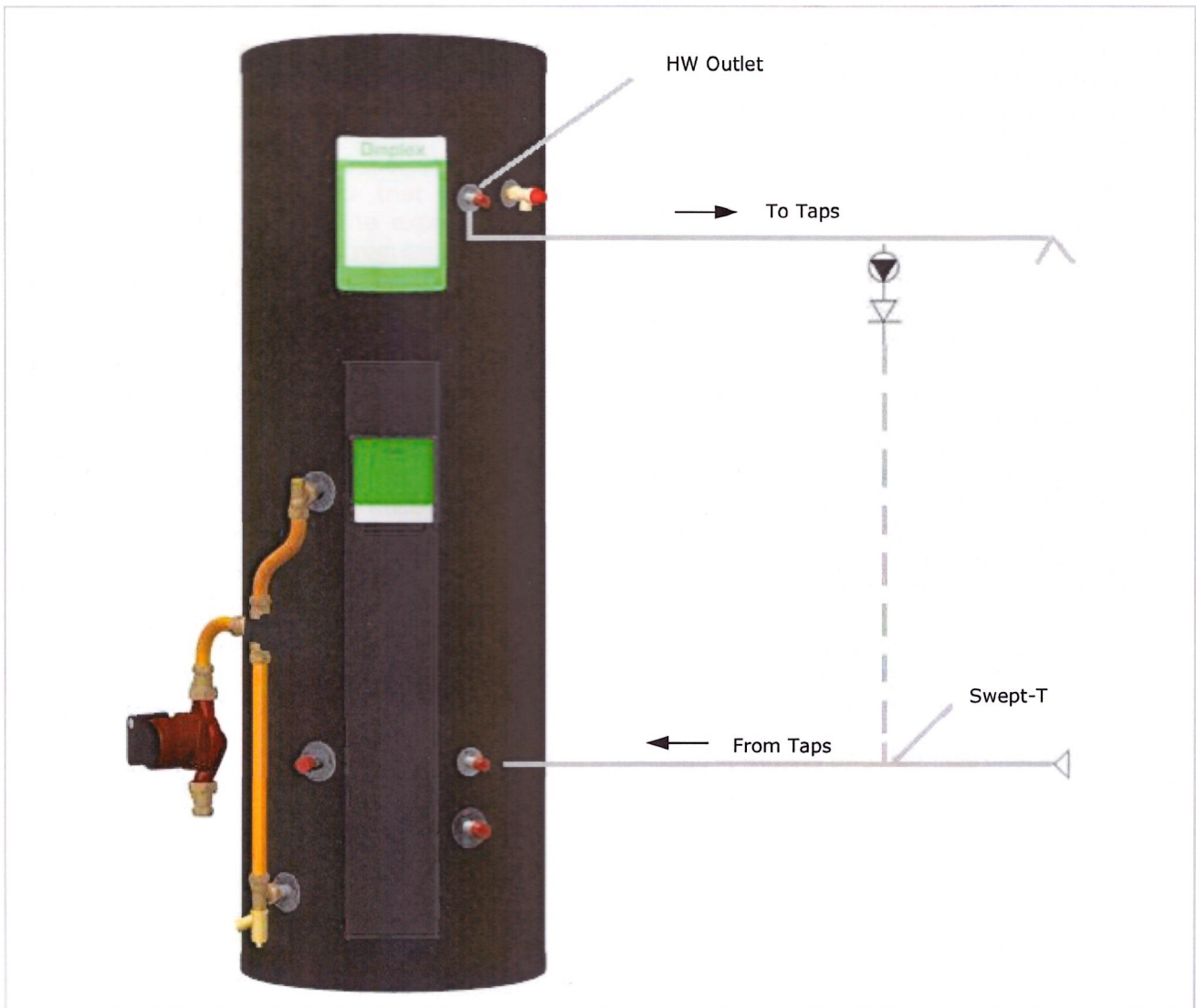

Figure 12: Secondary return loop

6 Commissioning

At the time of commissioning, complete all relevant sections of the Benchmark Checklist located on the inside back pages of this document.

The following commissioning procedures only detail the required steps to be taken for the potable water loop and not for the heat pump loop:

- 1) Before making any water mains connections to the inlet control group, flush the mains pipework out to ensure all debris has been removed so as not to damage the strainer within the combination valve.
- 2) Make final mains connection on combination valve and check all connections and joints to ensure they have been tightened and secured correctly.
- 3) Before turning on the mains supply to the cylinder a hot water tap should be opened, preferably on the same floor or the floor below where the cylinder is located.
- 4) Check the pre-charge in the expansion vessel and ensure it is at least 3 bar. Note actual pressure on label on expansion vessel.
- 5) Turn on the supply to the cylinder and fill until water runs from the open hot water tap. Continue to flush the system until all debris has been removed.
- 6) Close the hot water tap.
- 7) Check all joints for leaks, even those not having been altered especially when replacing a vented cylinder.
- 8) Open temperature and pressure relief valve to ensure proper discharge and check after closing that valve is not dripping.
- 9) Open expansion relief valve to ensure proper discharge and check after closing that valve is not dripping.
- 10) Check all shower outlets, toilet cisterns and other draw off points for leaks or dripping (especially when replacing a vented unit). Open all water outlets to purge air from pipe work and ensure proper operation.
- 11) Adjust timer programmer and cylinder thermostat settings in accordance with client requirements.
- 12) Follow the instructions for commissioning the heat pump as per heat pump installation manual.
- 13) Commission the user interface as per UI installation manual.
- 14) Instruct user in the operation of the cylinder, heat pump and UI. Hand over all manuals and advise the owner of annual service requirements.
- 15) Complete the technical data label on the cylinder with legible and permanent writing.

7 Maintenance

After servicing, complete the relevant Service Record section of the Benchmark Checklist located on the inside back pages of this document. To meet with warranty requirements, the cylinder must be serviced annually.



The maintenance of this appliance must be carried out by a suitably qualified person only. It is recommended to maintain the unit on an annual basis. Isolate all electrical supplies from the unit before commencing work. Danger of electrical shock!

- 1) Draw some water from cold water tap and retain in container.
- 2) Isolate cold water mains supply from cylinder.
- 3) Briefly open temperature and pressure relief valve, assure safe discharge and check that valve is not dripping when closed.
- 4) Briefly open expansion relief valve, assure safe discharge and check that valve is not dripping when closed. The expansion relief valve should be operated regularly to remove lime deposits and to verify that it is not blocked.
- 5) Open hot water tap and release remaining pressure from unit.
- 6) If the system is drained completely for an internal inspection, ensure the hot water tap remains open, connect a hose to the drain valve and ensure a safe discharge.
- 7) Note the set pressure of the pressure reducing valve. Remove cartridge and clean strainer in water provided in container. Re-assemble pressure reducing valve ensuring the correct pressure is set.

- 8) Periodically the immersion heaters should be removed cleaned and the unit flushed out. Check the O-ring seal for damage and replace if necessary.
- 9) Check electrical wiring connections and the condition of the cable of the immersion heater, the thermostat and the connections on the PCB.
- 10) The immersion heater boss can also be used for access to view the internal components of the cylinder.
- 11) Re-commission unit (see chapter 6).

If the cylinder is not in use for excess of 1 month, it must be drained down by a competent person and recommissioned before use.

Note: The immersion must be switched off at the mains before draining the cylinder.

If replacement parts are required, please see Figure 13 for part descriptions and part numbers.



CLEANING INSTRUCTIONS: Clean outer cladding of cylinder with a soft cloth dampened with warm water only. Do not use abrasive or aggressive cleaning materials, such as alcohol or petroleum based solvents, as this may damage the surface of the product.



Waste electrical products should not be disposed of with household waste. Please recycle where facilities exist. Check with your Local Authority or retailer for recycling advice.

8 Spare Parts

























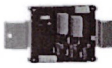

Description		Part No
22mm x 3bar Inlet control group		R00041-1
Inlet control group PRV cartridge		R00009-1
12 litre expansion vessel		R00044-2
18 litre expansion vessel		R00045-2
24 litre expansion vessel		R00046-2
Expansion vessel fixing kit		R00094-1
DN16 3/4" BSP x 1000 flex pipe		R00095-1
1/2" BSP T&P valve		R00020-1
15 x 22 straight PE tundish		R00047-1
1 3/4" M BSP 3kW Imm CW Stat		R03232-1
Immersion heater element		R01958-1
Imm heater rodstat		R01959-1
3kW Titanium Imm htr CW rodstat		R03586-1
22 mm 12l HP40A CYL Safety Kit		R02614-4
22 mm 18l HP40A CYL Safety Kit		R02615-4
22 mm 24l HP40A CYL Safety Kit		R02616-4
A Class PCB Asm		R02494-6
Connector Block A Class Asm		R03181-3
Relay PCB Board Spares Asm		R04317-1
HT Cutout Stat		R00959-1
Enclosure Hood		R02467-3
Hood Top Enclosure Kit		R03728-1
Hood Bottom Enclosure Kit		R03731-1
Relay Housing Bracket		R04003-1
Thread sealant		R00836-1
A Class HP Cylinder Installation & User Instructions manual		R02583-16
Terms and conditions		R01020-3

Figure 13: Replacement Part Numbers for Heat Pump Range of Cylinders

9 Technical Data and Product Fiche

9.1 A Class Heat Pump Buffer Range

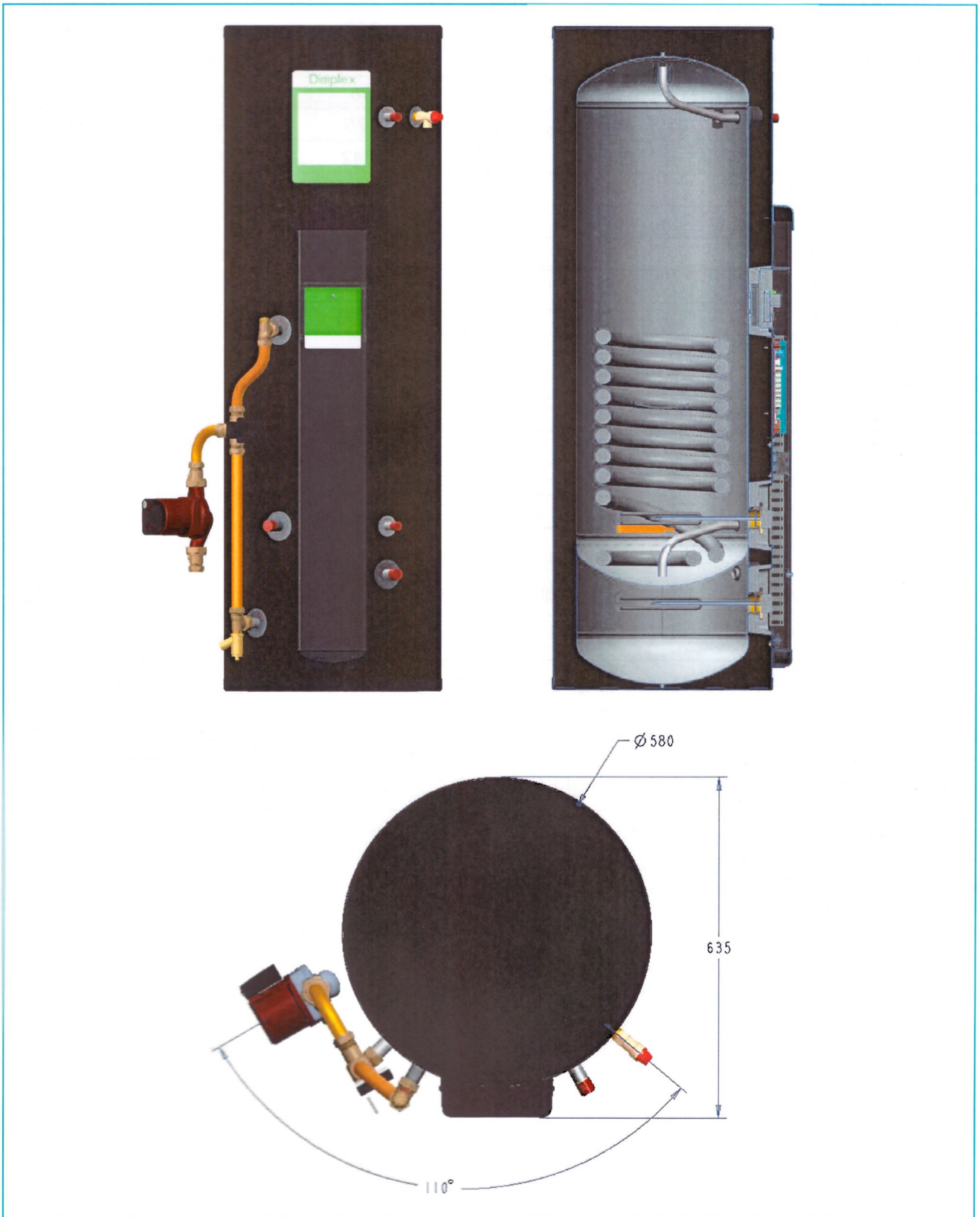

Figure 14: A Class Heat Pump Cylinder and Cross-Section (For Reference Only)

Technical Data

A Class Heat Pump Cylinder Range - Dimensions			
Reference	150	210	250
Actual Capacity [l]	145 + 40	208 + 40	245 + 40
Weight [kg]	42	50	62
Weight full [kg]	227	298	347
Reheat time [mins]*	8	13	18
Average draw off temperature [°C]*	58	58	60
Hot water draw off capacity (l)* / draw off flow rate (l/s)	125	193	246
	0.42	0.42	0.42
Heat loss [kWh/24h]*	1.11	1.45	1.51
Height [mm]	1380	1765	2025
Outer Diameter [mm]	580	580	580
HW Outlet [mm]	1150	1525	1800
T&P Valve [mm]	1150	1525	1800
Secondary Return [mm]	-	-	-
CW Inlet [mm]	440	440	440
HP Buffer Flow/HP Flow to Buffer [mm]	180	180	180
HP Buffer Flow/Buffer Flow to HP [mm]	312	312	312
HP Return/DHW Return [mm]	440	440	440
HP Flow/DHW Flow [mm]	960	960	960

Table 3: A Class Heat Pump Cylinder Dimensions

Note: All measurements are taken from the base of the cylinder to the mid-point on the item.

* Determined in accordance with EN12897 test procedures.

A Class Heat Pump Cylinder Range – Product Fiche			
Reference	ECS150HP40A-580	ECS210HP40A-580	ECS250HP40A-580
Energy Rating	B	B	B
Standing Loss [W]	46	60	63
Actual Capacity [L]	145	208	245

Table 4: A Class Heat Pump Cylinder Product Fiche

A Class Heat Pump Cylinder Range – Product Features			
Actual capacity [L]	145 + 40	208+40	245 + 40
Materials - inner cylinder - outer cylinder - inlet/outlet - coils - insulation	Duplex stainless steel LDX2101 ABS/HIPS Stainless steel Stainless steel 60mm PU foam (GWP=1, ODP=0)		
Maximum operating conditions - potable water temperature - heating water temperature - operating pressure - max. design pressure	70°C 95°C 3 bar 6 bar		
Cold water supply - minimum dynamic pressure - maximum static pressure - minimum flow rate	1.5 bar 12 bar 15 l/min		
Connections - cold water inlet - hot water outlet - coil flow and return	22mm stainless steel 22mm stainless steel 28mm stainless steel		
Coil specification - heat pump coil surface area [m ²] - HX performance heat pump coil [kW] - max. working pres. [Bar]	2.2 46 43 42 3		
Immersion heater	1 ¾ M BSP 3kW @ 240 V		
Thermostatic control - direct input - indirect input	Rod stat with variable and high limit cut out Rod stat with variable and high limit cut out		
Safety components - pressure reducing valve and strainer - expansion relief valve - temperature and pressure relief valve - factory pressure test	3 bar 6 bar ½" 7 bar/90°C 12 bar		
Other features	Over 60% in volume from recycled materials# Surface mounted sensor devices for compatibility and ease of maintenance		
Approvals	KIWA approval number:- 1309705		
Guarantee (*) - inner cylinder - immersion heaters - other components	25 yrs. 2 yrs. - excluding the effects of lime scale or other water borne contaminants 2 yrs. - excluding expansion vessel membrane pressure		

Table 5: A Class Heat Pump Cylinder Product Fiche and Features

Not including insulation

(*) subject to terms and conditions

9.2 Cylinder Heat Exchanger Pressure Drop

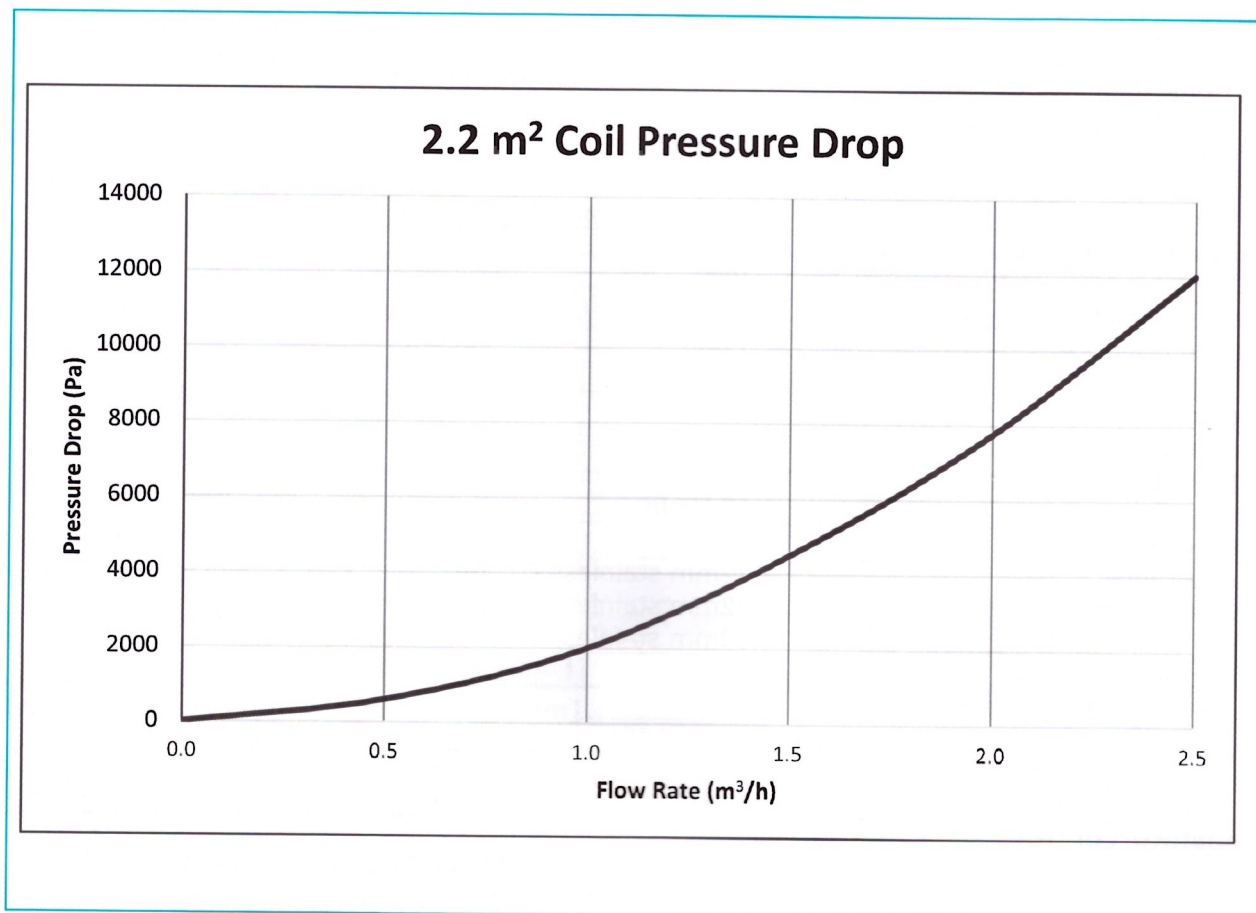

Figure 15: Heat Exchanger Pressure Drop for 2.2m² Coils

9.3 Cylinder Attainable Temperature

The heat pump heating system must be commissioned by a trained installer. Ensuring correct installation of the system will allow a water temperature of 60°C to be obtained inside the cylinder during DHW preparation.

This is true for all cases when ambient conditions are between -2°C and +25°C. For other operating conditions, i.e. -2°C < ambient > 25°C, cylinder temperatures of approximately 55°C can be expected.

The A Class heat pump will be able to achieve 60°C without immersion back up in all of the A Class cylinders, so long as the flow rate specified in the instructions is met, the pipes are insulated and the pipe runs from the heat pump to the cylinder and back are less than 15m.

10 User Instructions

10.1 General

"This appliance can be used by children aged from 8 years and above and persons with reduced physical, sensory or mental capabilities or lack of experience and knowledge if they have been given supervision or instruction concerning use of the appliance in a safe way and understand the hazards involved. Children shall not play with the appliance. Cleaning and user maintenance shall not be made by children without supervision."

Please read the following statements carefully as it affects your warranty:

Please ensure that the installer has fully completed the Benchmark Checklist on the inside back pages of this document and that you have signed it to say that you have received a full and clear explanation of its operation. The installer is legally required to complete a commissioning checklist as a means of complying with the appropriate Building Regulations Part G3 (England and Wales), Part P of Northern Ireland and Section 6 of Scotland.

All installations must be notified to Local Area Building Control either directly or through a Competent Persons Scheme. A Building Regulations Compliance Certificate will then be issued to the customer who should, on receipt, write the Notification Number on the Benchmark Checklist.

This product should be serviced annually to optimise its safety, efficiency and performance. The service engineer should complete the relevant Service Record on the Benchmark Checklist after each service.

The Benchmark Checklist will be required in the event of any warranty work.

10.2 Operation

Once the system has been fully commissioned, no user intervention should be required to fully enjoy the comfort and benefits of the unvented hot water cylinder.

The hot water temperature can be set to various requirements.

When turning on a hot tap for the first time after a heat up period there might be a short surge of water. This is normal in unvented systems and does not constitute a fault. Sometimes the water may appear milky – this is due to very fine air bubbles in the water which will clear quickly.

10.3 Water Temperature Direct Electric Heating

The heat pump should be used for production of DHW. However, if the desired water temperature is not achieved the immersion heater will activate.

 Before removing the cover from the immersion heater isolate appliance using isolating switch! Danger of electrical shock! Only use suitable electrically insulated equipment when working inside immersion housing.

The hot water temperature achieved by the direct electric heating element can be adjusted by removing the cover from the immersion heater and adjusting the dial up or down as indicated in Figure 16. As a default the maximum setting is selected, which is equivalent to 60°C.

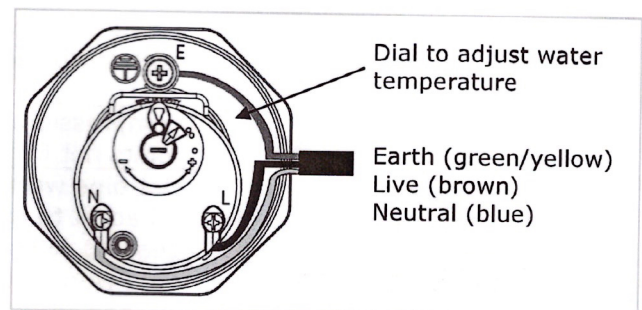



Figure 16: Adjustment Water Temperature Direct Electric Heating Element

10.4 Maintenance

 **The maintenance of this appliance must be carried out by a suitably qualified person only. It is recommended to maintain the unit on an annual basis. Isolate all electrical supplies from the unit before commencing work. Danger of electrical shock! See Section 7.**

10 User Instructions

10.1 General

"This appliance can be used by children aged from 8 years and above and persons with reduced physical, sensory or mental capabilities or lack of experience and knowledge if they have been given supervision or instruction concerning use of the appliance in a safe way and understand the hazards involved. Children shall not play with the appliance. Cleaning and user maintenance shall not be made by children without supervision."

Please read the following statements carefully as it affects your warranty:

Please ensure that the installer has fully completed the Benchmark Checklist on the inside back pages of this document and that you have signed it to say that you have received a full and clear explanation of its operation. The installer is legally required to complete a commissioning checklist as a means of complying with the appropriate Building Regulations Part G3 (England and Wales), Part P of Northern Ireland and Section 6 of Scotland.

All installations must be notified to Local Area Building Control either directly or through a Competent Persons Scheme. A Building Regulations Compliance Certificate will then be issued to the customer who should, on receipt, write the Notification Number on the Benchmark Checklist.

This product should be serviced annually to optimise its safety, efficiency and performance. The service engineer should complete the relevant Service Record on the Benchmark Checklist after each service.

The Benchmark Checklist will be required in the event of any warranty work.

10.2 Operation

Once the system has been fully commissioned, no user intervention should be required to fully enjoy the comfort and benefits of the unvented hot water cylinder.

The hot water temperature can be set to various requirements.

When turning on a hot tap for the first time after a heat up period there might be a short surge of water. This is normal in unvented systems and does not constitute a fault. Sometimes the water may appear milky – this is due to very fine air bubbles in the water which will clear quickly.

10.3 Water Temperature Direct Electric Heating

The heat pump should be used for production of DHW. However, if the desired water temperature is not achieved the immersion heater will activate.

 Before removing the cover from the immersion heater isolate appliance using isolating switch! Danger of electrical shock! Only use suitable electrically insulated equipment when working inside immersion housing.

The hot water temperature achieved by the direct electric heating element can be adjusted by removing the cover from the immersion heater and adjusting the dial up or down as indicated in Figure 16. As a default the maximum setting is selected, which is equivalent to 60°C.

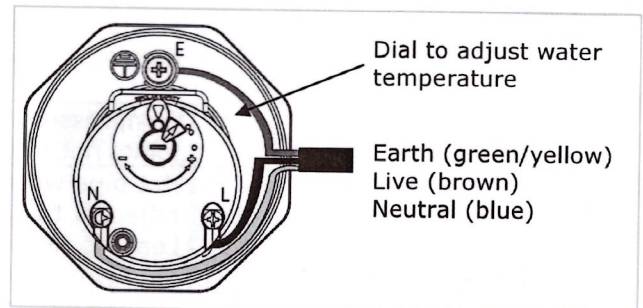



Figure 16: Adjustment Water Temperature Direct Electric Heating Element

10.4 Maintenance

 **The maintenance of this appliance must be carried out by a suitably qualified person only. It is recommended to maintain the unit on an annual basis. Isolate all electrical supplies from the unit before commencing work. Danger of electrical shock! See Section 7.**

10.5 Troubleshooting

Fault	Cause	Solution
A No water from hot water taps	A.1 Stop valve closed A.2 Strainer blocked A.3 Pressure reducing valve fitted against flow	A.1 Open stop valve A.2 Turn water supply off, clean strainer and re-commission A.3 Re-fit with arrow showing in direction of flow
B No hot water	B.1 Timer/Programmer not set correctly B.2 Auxiliary heating malfunction B.3 Direct heating malfunction B.4 Auxiliary/direct heating high limit thermostat has tripped	B.1 Set timer/programmer correctly B.2 Consult auxiliary heating system instructions B.3 Call for qualified person to check immersion heater B.4 Reset limit thermostat(s) and inform installer
C Intermittent water discharge through tundish on warm-up	C.1 Expansion vessel lost charge	C.1 Check expansion vessel (see commissioning / maintenance, top up or replace)
D Continuous discharge	D.1 Pressure reducing valve not working D.2 Pressure relief or T&P valve not seating correctly D.3 Malfunction of high limit thermostat or appliance	D.1 Check pressure after valve and replace if faulty D.2 Manually lift valve once or twice to clear debris, otherwise replace D.3 Check function of thermostats and appliances
E Leakage from casing	E.1 Compression/threaded joints not formed correctly	E.1 Re-seal joints with care
F Hot water from cold tap	F.1 Hot pipe work being routed adjacent to cold pipe work F.2 Leaking seal in mixer tap	F.1 Insulate hot pipe work or re-route F.2 Replace seals in mixer tap
G Metallic noise from system	G.1 Pipe work not sufficiently supported	G.1 Add extra pipe work fixings
H Humming noise from system during re-heat	H.1 Air in system H.2 Flow rate well in excess of specification	H.1 Bleed system thoroughly and re-pressurize H.2 Reduce pump speed

Table 6: Troubleshooting Guide

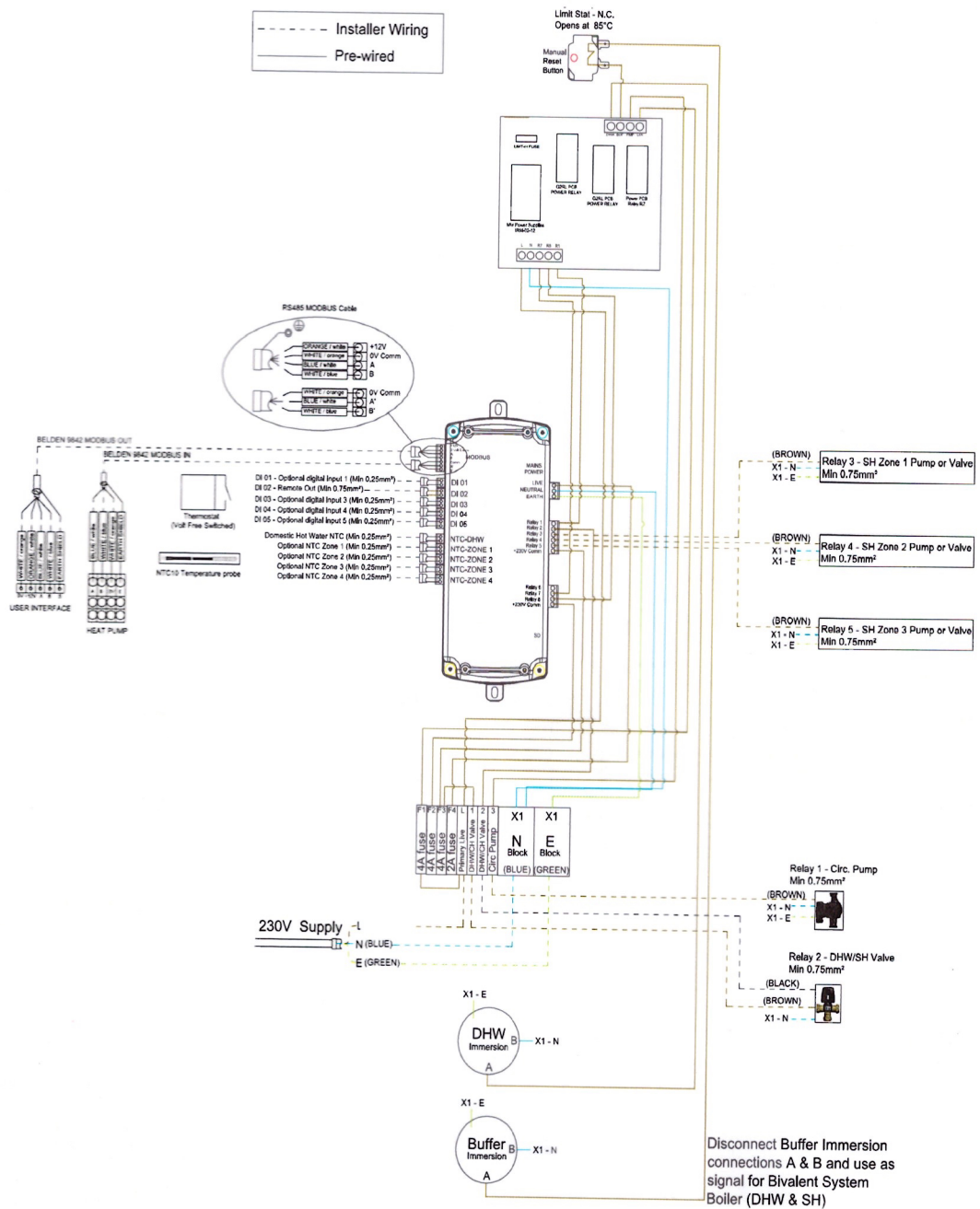

Figure 17: A Class Cylinder Wiring Overall View

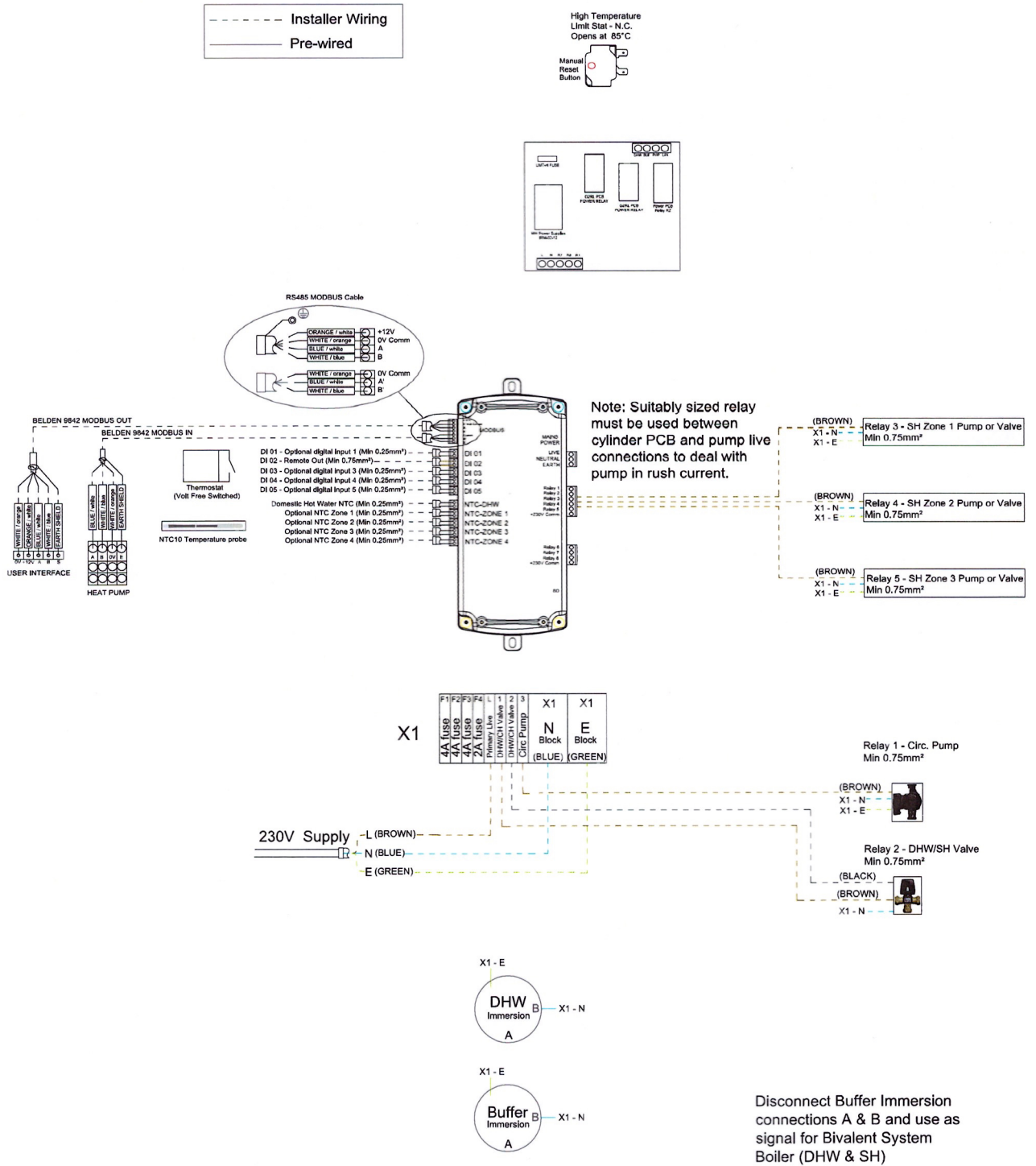

Figure 18: A Class Installer Wiring Overall View

Disregarding the instructions given in this manual in its entirety and any relevant regulations, standards and codes of practice will void the guarantee of this product. GDC Group Ltd reserves the right to revise products, literature and guarantee terms without prior notice due to a policy of continuous improvement.

To speak to customer services please contact:

GDC Group Ltd

Millbrook House Grange Drive, Hedge End,
Southampton SO30 2DF

Telephone: 0844 879 3588

Fax: 0844 879 3583

Email: customer.services@gdcgroup.co.uk

www.dimplex.co.uk



ECS210HP40A-580

000110T



ENERG

енергия · ενεργεια



Dimplex

ECS210HP40A-580

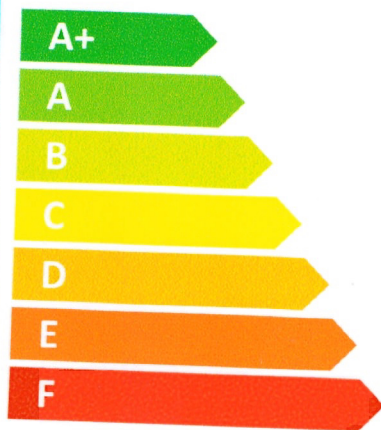

B

60_w

208_L

2017

812/2013

R03486-2