

3.3 Face Plates & Switches

CLICK MODE

Scolmore
GROUP

Scolmore International Ltd
1 Scolmore Park, Landsberg
Lichfield Road Industrial Estate
Tamworth, Staffordshire B79 7XB

t: 01827 63454
f: 01827 63362
e: sales@scolmore.com
w: www.scolmore.com

DECLARATION OF CONFORMITY

1. Issuer Name Scolmore International Limited
2. Issuer Address 1 Scolmore Park, Landsberg,
Lichfield Road Industrial Estate,
Tamworth, Staffordshire, B79 7XB
3. Object of Declaration MODE Range
4. The object of the declaration described above is in conformity with the requirements of the following documents:
5. Document No Title
2004/108/EC EMC Directive
2006/95/EC Low Voltage Directive
2011/65/EU RoHS Directive
1907/2006/EC Reach Regulations
94/62/EC Packaging Directive
6. All products contained within this range comply with their relevant standards and requirements.
7. The declaration of conformity is made in relation to the associated tests carried out and verified by our suppliers and their authorized test facilities.

In conjunction with the above all manufacture and process controls are in accordance with ISO 9001:2008

Signed for and on behalf of:
Scolmore International Limited



Steven Bettson BSc – Senior Technical Support Engineer



Company Registration No. 2513009

CLICK OVA

3 July 2014

MODE™

CLICK®

ScolmoreGROUP



45A Cooker Switches & Socket Outlets



The smooth modern lines of the MODE accessory plate will fit easily into traditional and contemporary designs alike.

MODE 45A Cooker Switches and socket outlets are designed to fit effortlessly with the range, with simple installation to enhance the décor of any area.

Scolmore International Ltd, 1 Scolmore Park, Landsberg, Lichfield Road Ind. Estate, Tamworth, Staffordshire, B79 7XB
Telephone: 01827 63454 **Facsimile:** 01827 63362
E-mail: sales@scolmore.com, technical@scolmore.com **Website:** www.scolmore.com



45A Cooker Switches & Socket Outlets

Product Range

45A Plate Switches (Red Rockers)

| | |
|--------|----------------------------------------------------|
| CMA200 | 45A 1 Gang Single Cooker Switch |
| CMA201 | 45A 1 Gang Single Cooker Switch with Neon |
| CMA202 | 45A 2 Gang Single Cooker Switch |
| CMA203 | 45A 2 Gang Single Cooker Switch with Neon |
| CMA204 | 45A Cooker Switch with 13A Switched Socket |
| CMA205 | 45A Cooker Switch with 13A Switched Socket & Neons |

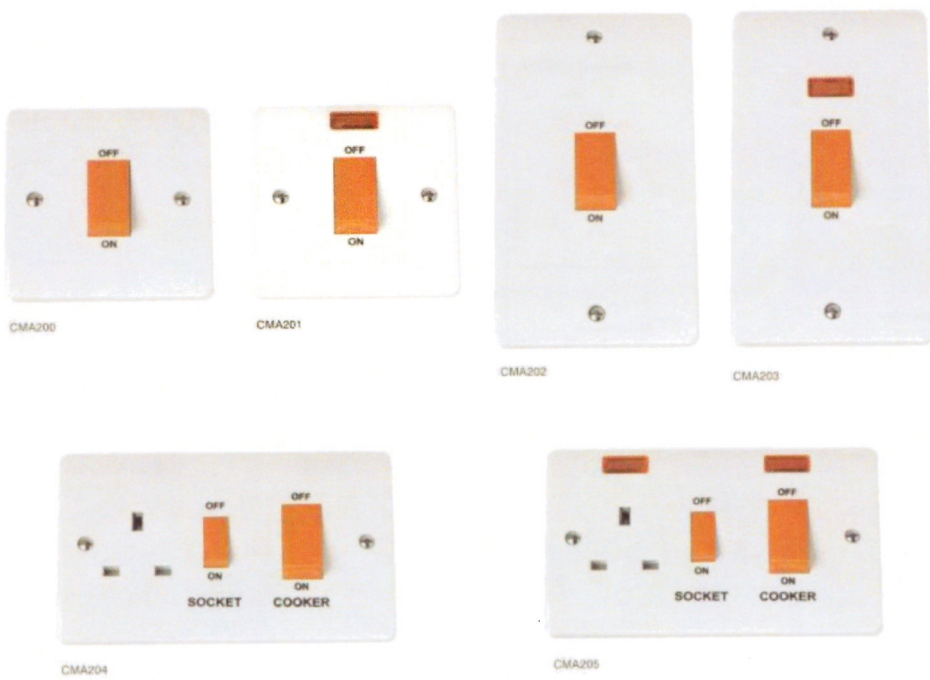

Errors & Omissions excluded. Specification is subject to change without notice. V1.0

Scolmore International Ltd, 1 Scolmore Park, Landsberg, Lichfield Road Ind. Estate, Tamworth, Staffordshire, B79 7XB

Telephone: 01827 63454 **Facsimile:** 01827 63362
E-mail: sales@scolmore.com, technical@scolmore.com **Website:** www.scolmore.com



45A Cooker Switches & Socket Outlets

Product Range

45A Plate Switches (White Rockers)

| | |
|--------|----------------------------------------------------|
| CMA500 | 45A 1 Gang Single Cooker Switch |
| CMA501 | 45A 1 Gang Single Cooker Switch with Neon |
| CMA502 | 45A 2 Gang Single Cooker Switch |
| CMA503 | 45A 2 Gang Single Cooker Switch with Neon |
| CMA504 | 45A Cooker Switch with 13A Switched Socket |
| CMA505 | 45A Cooker Switch with 13A Switched Socket & Neons |



CMA500

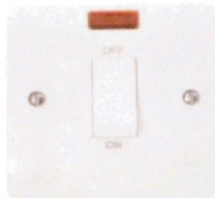

CMA501

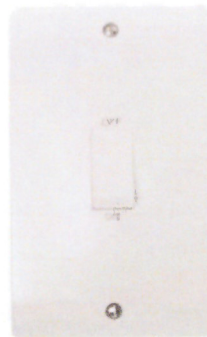

CMA502



CMA503



CMA504

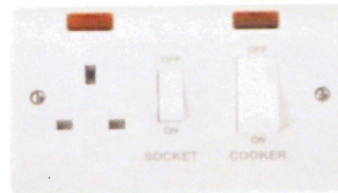

CMA505

Errors & Omissions excluded. Specification is subject to change without notice.

V1.0

Scolmore International Ltd, 1 Scolmore Park, Landsberg, Lichfield Road Ind. Estate, Tamworth, Staffordshire, B79 7XB
Telephone: 01827 63454 **Facsimile:** 01827 63362
E-mail: sales@scolmore.com, technical@scolmore.com **Website:** www.scolmore.com

MODETM

CLICK[®]
ScolmoreGROUP

45A Cooker Switches & Socket Outlets

Product Dimensional Drawings (mm)

CMA200, CMA500

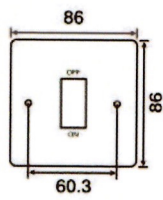

CMA201, CMA501

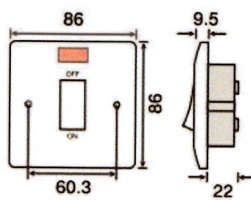

CMA202, CMA502

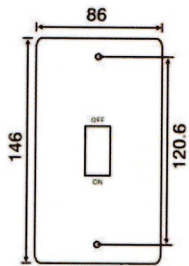

CMA203, CMA503

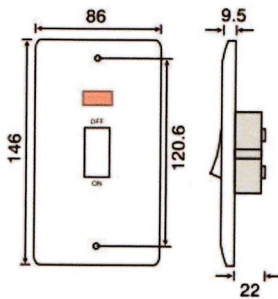

CMA204, CMA504

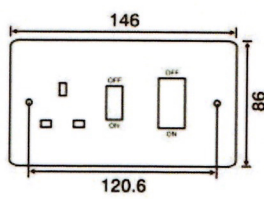

CMA205, CMA505

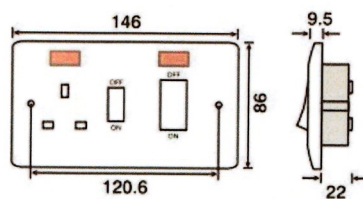

Prices & Dimensions excluded. Specification is subject to change without notice.

V1.0

Scolmore International Ltd, 1 Scolmore Park, Landsberg, Lichfield Road Ind. Estate, Tamworth, Staffordshire, B79 7XB

Telephone: 01827 63454

E-mail: sales@scolmore.com, technical@scolmore.com

Facsimile: 01827 63362

Website: www.scolmore.com

MODE™

CLICK®
ScolmoreGROUP

45A Cooker Switches & Socket Outlets

Wiring Diagrams

45A Cooker Switch

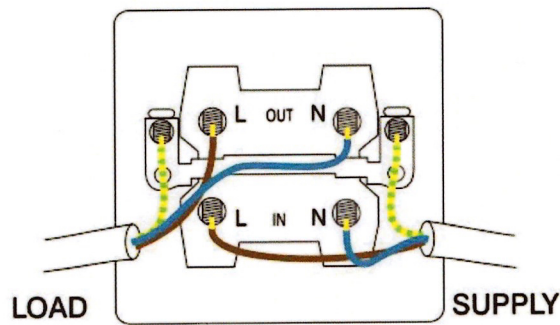

45A Cooker Switch with Socket

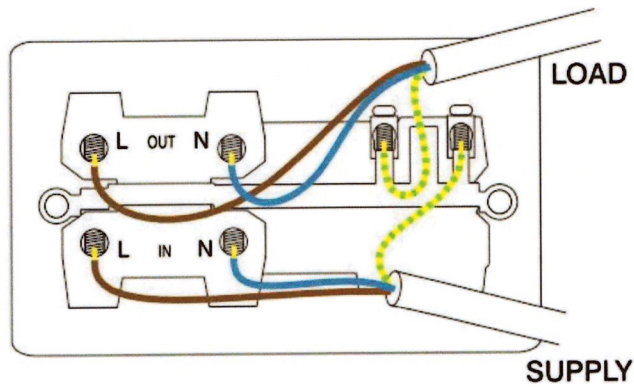

Errors & Omissions excluded. Specification is subject to change without notice.

V1.0

Scolmore International Ltd, 1 Scolmore Park, Landsberg, Lichfield Road Ind. Estate, Tamworth, Staffordshire, B79 7XB

Telephone: 01827 63454

E-mail: sales@scolmore.com, technical@scolmore.com

Facsimile: 01827 63362

Website: www.scolmore.com



45A Cooker Switches & Socket Outlets

Technical Specification

45A Cooker Switches & Socket Outlets

| | |
|---------------------------------|------------------------------------------------------------------------------------------------------------------------------------------------------------------------------------------------------|
| Material Composition | Front Plate, Rocker Switch & Rear Housing: Urea Terminals: Brass, Terminal Screws: Steel & Yellow Passivated Internal Mechanism: Formed Press Brass Silver "on-lay" Copper / Brass Contacts |
| Voltage | 240V~ 50Hz |
| Current Rating | 45A |
| Terminal Size | 6mm ø |
| Torque Value | 2.5Nm |
| Cable Size | 4 x 4mm ² , 3 x 6mm ² or 1 x 10mm ² |
| Double Pole | Yes |
| Twin Earth | Yes |
| Back Box Depth | 35mm - 47mm |
| Warranty | 20 Years |
| Anti Microbial Certified | Yes |
| IP Rating | IP20 |
| Operational Temperature | -5° to +40°C |
| Standards | The Low Voltage Directive 2006/95/EC, Modified ISO 22196 EN 60669-1:1999 + A1:2002 + A2:2008 (BS EN 60669-1:2000) BS 4177:1992 BS 1363-2:1995 + A4 : 2012 (Socket Outlet) |

Additional Information

Ensure that the mains supply is isolated before commencing installation and refer to the circuit diagram with the relevant product.

Bare earth cables must always be covered with appropriate sleeving and wired to the earth terminal.

All white moulded accessories are manufactured using Urea Formaldehyde, which has similar inherent properties to antimicrobial additives that inhibit the growth of infectious diseases. All products were independently tested and achieved a 99.9% kill rate across all four types of the strains of bacteria - MRSA, E-Coli, Salmonella, and Klebsiella Pneumoniae.

Errors & Omissions excluded. Specification is subject to change without notice.

V1.0

Scolmore International Ltd, 1 Scolmore Park, Landsberg, Lichfield Road Ind. Estate, Tamworth, Staffordshire, B79 7XB
Telephone: 01827 63454 **Facsimile:** 01827 63362
E-mail: sales@scolmore.com, technical@scolmore.com **Website:** www.scolmore.com

CLICK MODE

Scolmore
GROUP

Scolmore International Ltd
1 Scolmore Park, Landsberg
Lichfield Road Industrial Estate
Tamworth, Staffordshire B79 7XB

t: 01827 63454
f: 01827 63362
e: sales@scolmore.com
w: www.scolmore.com

DECLARATION OF CONFORMITY

1. *Issuer Name* Scolmore International Limited
2. *Issuer Address* 1 Scolmore Park, Landsberg,
Lichfield Road Industrial Estate,
Tamworth, Staffordshire, B79 7XB
3. *Object(s) of Declaration* Mode Range
- a. *Group* 45A Switches & 45A Cooker Control Units
- b. *Model No.* CMA200, CMA201, CMA202, CMA203, CMA204, CMA205, CMA500,
CMA501, CMA502, CMA503, CMA504, CMA505

4. *The object of the declaration described above is in conformity with the requirements of the following Legislations:*

| Document No | Title |
|-------------|-----------------------|
| 2006/95/EC | Low Voltage Directive |

5. *All products contained within the aforementioned comply with the relevant standards and requirements listed below.*

BS EN 60669-1 : 1999 + A1 : 2002 + A2 : 2008 (BS EN 60669-1 : 2000)
BS 4177: 1992 + AMD 1:1993, 2:1997, 3:2004, 4 : 2007
BS 1363-2 : 1995 + A4 : 2012

6. *I hereby declare that the equipment named above has been designed to comply with the relevant sections of the above referenced specifications. The unit complies with all applicable Essential Requirements of the Directives.*

In conjunction with the above all manufacture and process controls are in accordance with ISO 9001:2008

Signed, for and on behalf of: Scolmore International Limited

Steven Bettson BSc - Senior Technical Support Engineer

CE 13



Company Registration No. 2513009

CLICK

OVI